

**This electronic collection of documents is provided
for the convenience of the user
and is Not a Certified Document –**

**The documents contained herein were originally issued
and sealed by the individuals whose names and license
numbers appear on each page, on the dates appearing
with their signature on that page.**

**This file or an individual page
shall not be considered a certified document.**

See Sheet 1A For Index of Sheets
See Sheet 1B For Standard Symbology Sheet

STATE OF NORTH CAROLINA
DIVISION OF HIGHWAYS

MACON COUNTY

**LOCATION: BRIDGE #244 OVER NORTH FORK COWEETA CREEK
ON SR 1114 (SHOPE RD)**
TYPE OF WORK: GRADING, PAVING, DRAINAGE, & CULVERT

STATE	STATE PROJECT REFERENCE NO.	SHEET NO.	TOTAL SHEETS
N.C.	B-6025	1	
STATE PROJ. NO.	F.A. PROJ. NO.	DESCRIPTION	
48220.1.1	1114(009)	P.E.	
48220.2.1	1114(009)	ROW & UTILITIES	
48220.3.1	1114(009)	CONSTRUCTION	

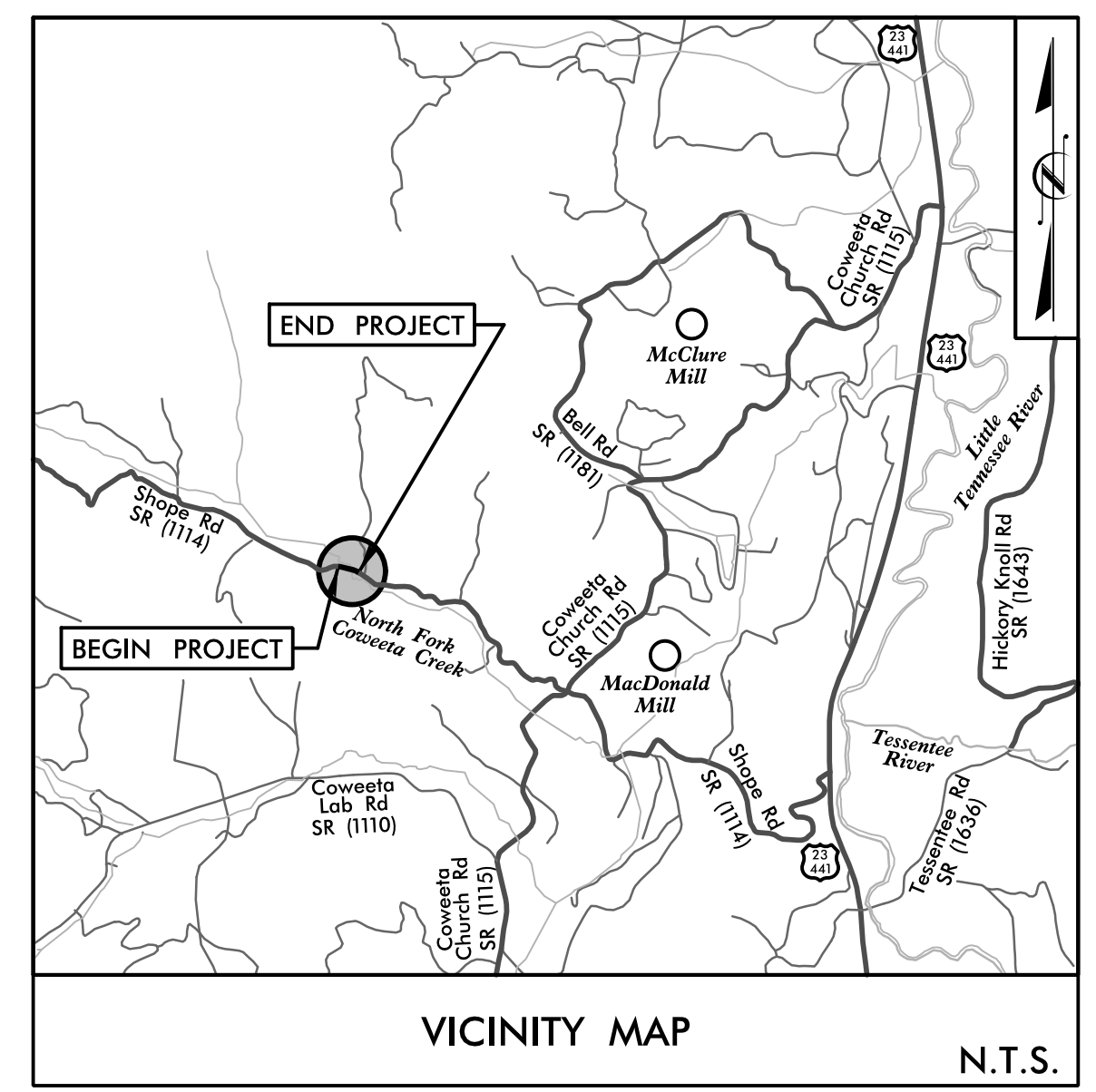
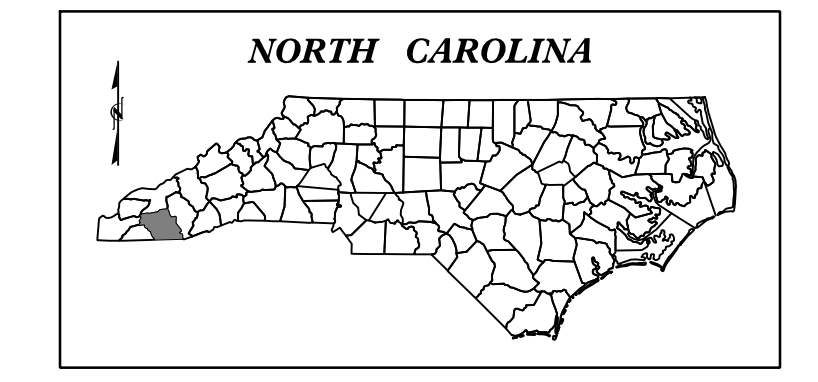

FINAL PLANS

PROJECT TIP: B-6025

CONTRACT: DN00480

BEGIN PROJECT TIP B-6025
-L- STA. 11 + 70.00

END PROJECT TIP B-6025
-L- STA. 15 + 50.00

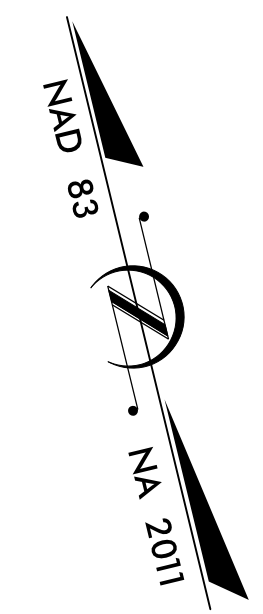
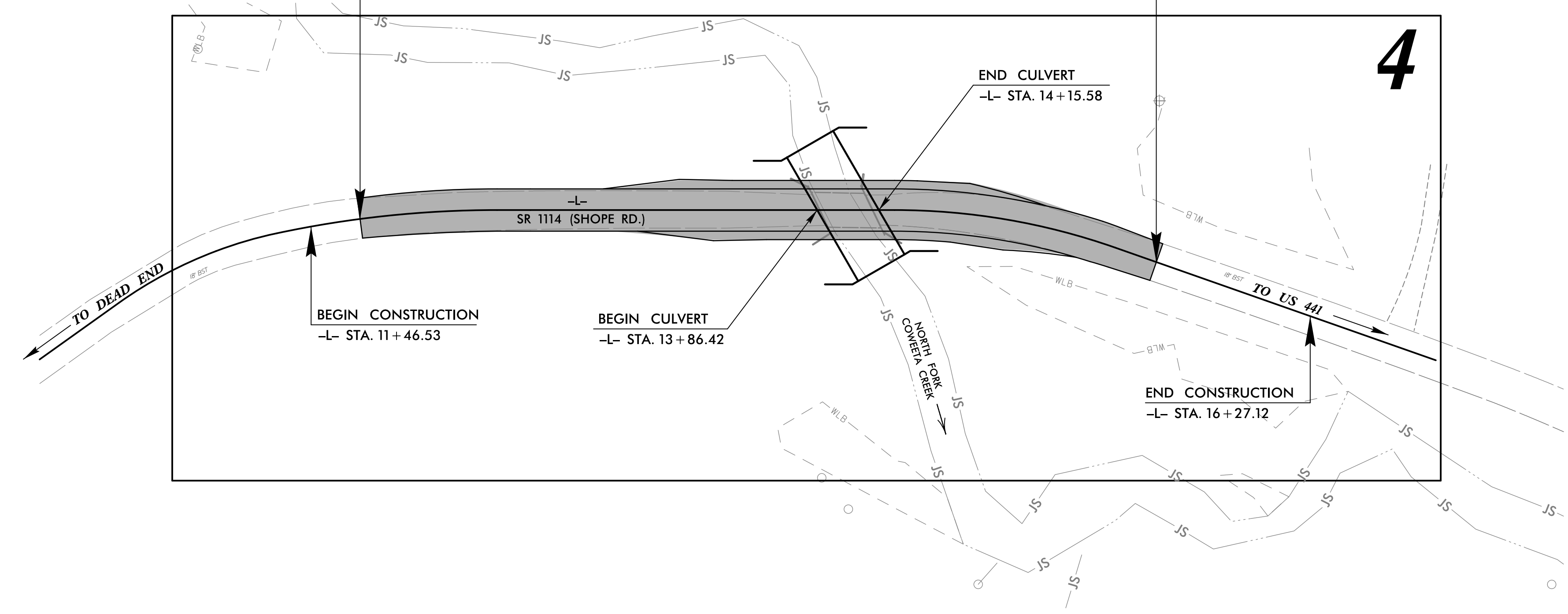

**DOCUMENT NOT CONSIDERED FINAL
UNLESS ALL SIGNATURES COMPLETED**

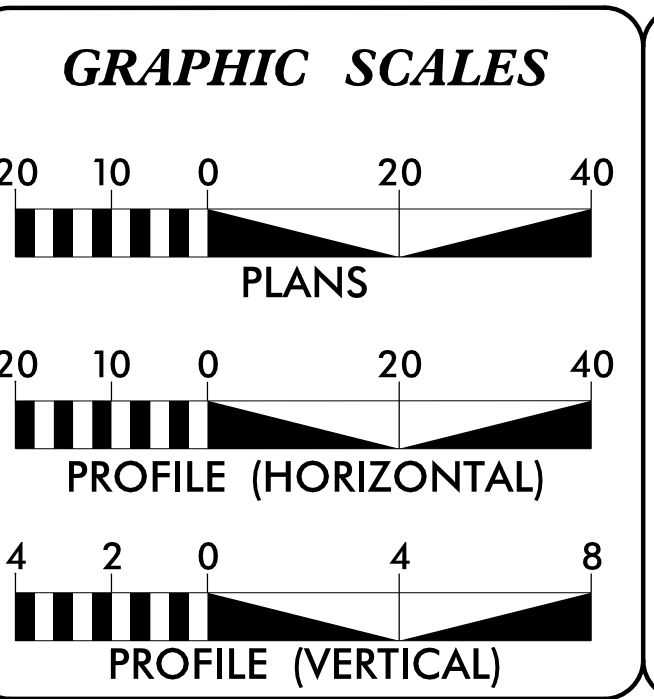

DESIGN DATA

ADT 2012 =	120
ADT 2025 =	240
DHV =	N/A
D =	N/A
T =	6%
V =	30 MPH

FUNC. CLASSIFICATION:
SUB REGIONAL TIER

PROJECT LENGTH

LENGTH OF ROADWAY PROJECT TIP B-6025 = 0.066 MILES
LENGTH OF STRUCTURE PROJECT TIP B-6025 = 0.006 MILES
TOTAL LENGTH OF PROJECT TIP B-6025 = 0.072 MILES

NCDOT CONTACT: ZACH SHULER, PE
Division Bridge Manager

PLANS PREPARED FOR THE NCDOT BY:

stv STV Engineers, Inc.
900 West Trade St., Suite 715
Charlotte, NC 28202
NC License Number F-0991

2024 STANDARD SPECIFICATIONS

RIGHT OF WAY DATE:
NOVEMBER 30, 2017

LETTING DATE:
APRIL 9, 2024

NIKKI T. HONEYCUTT, PE
PROJECT ENGINEER

MAAMOON K. ABDELAZIZ
PROJECT DESIGNER

HYDRAULICS ENGINEER

2/7/2024
SIGNATURE: DAVID C. MORRISON P.E.

ROADWAY DESIGN ENGINEER

2/7/2024
SIGNATURE: NIKKI T. HONEYCUTT P.E.

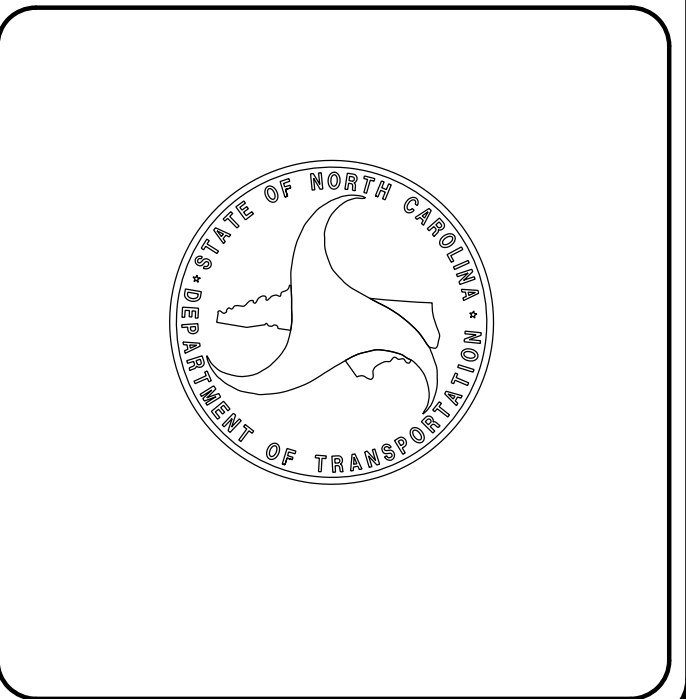

INDEX OF SHEETS

SHEET NUMBER	SHEET
1	TITLE SHEET
1A	INDEX OF SHEETS, GENERAL NOTES, AND LIST OF STANDARD DRAWINGS
1B	CONVENTIONAL SYMBOLS
RW01	SURVEY CONTROL TITLE SHEET
RW02C-1THRU RW02C-3	SURVEY CONTROL PLANSHEET
RW02D-1	PROP ALIGNMENT SHEET
RW03E-1	RIGHT OF WAY CONTROL SHEET
RW04	RIGHT OF WAY SHEET
2A-1	TYPICAL SECTIONS SHEET
2B-1	DETOUR SHEET
3B-1	SUMMARIES SHEET
3P-1	PARCEL DATA SHEET
4	PLAN AND PROFILE SHEETS
TMP-1 THRU TMP-5	TRAFFIC MANAGEMENT PLANS
PMP-1	PAVEMENT MARKING PLANS
EC-1 THRU EC-8	EROSION CONTROL PLANS
RF-1	REFORESTATION DETAIL SHEET
UO-1 THRU UO-2	UTILITIES BY OTHERS PLANS
X-1 THRU X-10	CROSS-SECTIONS
C-1 THRU C-3	CULVERT PLANS
SN	STANDARD STRUCTURAL NOTES

GENERAL NOTES

GENERAL NOTES: 2024 SPECIFICATIONS EFFECTIVE: 01-01-2024

GRADE LINE:
 GRADING AND SURFACING: THE GRADE LINES SHOWN DENOTE THE FINISHED ELEVATION OF THE PROPOSED SURFACING AT GRADE POINTS SHOWN ON THE TYPICAL SECTIONS. GRADE LINES MAY BE ADJUSTED AT THEIR BEGINNING AND ENDING AND AT STRUCTURES AS DIRECTED BY THE ENGINEER IN ORDER TO SECURE A PROPER TIE-IN.

CLEARING: CLEARING ON THIS PROJECT SHALL BE PERFORMED TO THE LIMITS ESTABLISHED BY METHOD II.

SUPERELEVATION: ALL CURVES ON THIS PROJECT SHALL BE SUPERELEVATED IN ACCORDANCE WITH STD. NO. 225.04 USING THE RATE OF SUPERELEVATION AND RUNOFF SHOWN ON THE PLANS. SUPERELEVATION IS TO BE REVOLVED ABOUT THE GRADE POINTS SHOWN ON THE TYPICAL SECTIONS.

SHOULDER CONSTRUCTION: ASPHALT, EARTH, AND CONCRETE SHOULDER CONSTRUCTION ON THE HIGH SIDE OF SUPERELEVATED CURVES SHALL BE IN ACCORDANCE WITH STD. NO. 560.01.

GUARDRAIL: THE GUARDRAIL LOCATIONS SHOWN ON THE PLANS MAY BE ADJUSTED DURING CONSTRUCTION AS DIRECTED BY THE ENGINEER. THE CONTRACTOR SHOULD CONSULT WITH THE ENGINEER PRIOR TO ORDERING GUARDRAIL MATERIAL.

RIGHT-OF-WAY MARKERS: ALL RIGHT-OF-WAY MARKERS ON THIS PROJECT SHALL BE PLACED BY CONTRACT IN ACCORDANCE WITH SECTION 801 OF THE 2024 NCDOT STANDARD SPECIFICATIONS FOR ROADS AND STRUCTURES.

SUBSURFACE PLANS: SUBSURFACE INFORMATION IS AVAILABLE ON THE STRUCTURE PORTION OF THIS PROJECT ONLY. THE CONTRACTOR SHOULD MAKE HIS OWN INVESTIGATION AS TO THE SUBSURFACE CONDITIONS.

TEMPORARY SHORING: SHORING REQUIRED FOR THE MAINTENANCE OF TRAFFIC NOT SHOWN ON THE PLANS WILL BE PAID FOR AT THE CONTRACT PRICE FOR "TEMPORARY SHORING."

UTILITIES: UTILITY OWNER ON THIS PROJECT IS FRONTIER COMMUNICATIONS. ANY RELOCATION OF EXISTING UTILITIES WILL BE ACCOMPLISHED BY OTHERS, EXCEPT AS SHOWN ON THE PLANS.

STANDARD DRAWINGS

2024 ROADWAY ENGLISH STANDARD DRAWINGS EFF. January, 2024









The following Roadway Standards as appear in "Roadway Standard Drawings" Highway Design Branch - N. C. Department of Transportation - Raleigh, N. C., Dated January, 2024 are applicable to this project and by reference hereby are considered a part of these plans:

STD.NO.	TITLE
DIVISION 2 - EARTHWORK	
200.02	Method of Clearing - Method II
225.02	Guide for Grading Subgrade - Secondary and Local
225.04	Method of Obtaining Superelevation - Two Lane Pavement
DIVISION 5 - SUBGRADE, BASES AND SHOULDERS	
560.01	Method of Shoulder Construction - High Side of Superelevated Curve - Method I
DIVISION 8 - INCIDENTALS	
862.01	Guardrail Placement
862.02	Guardrail Installation
DIVISION 11 - WORK ZONE TRAFFIC CONTROL	
1101.01	Detail Drawing for Two-way Undivided Work Zone Warning Signs
1101.02	Temporary Lane Closures
1101.04	Temporary Shoulder Closures
1101.05	Work Zone Vehicle Accesses
1110.01	Stationary Work Zone Signs - Mounting Height & Lateral Clearance
1110.02	Portable Work Zone Signs - Mounting Height & Lateral Clearance
1130.01	Drum
1145.01	Barricades - Type III
1150.01	Flagging Devices
DIVISION 12 - PAVEMENT MARKINGS, MARKERS AND DELINEATION	
1205.01	Pavement Markings - Line Types and Offsets
1261.01	Guardrail and Barrier Delineators - Installation Spacing
1261.02	Guardrail & Barrier Delineators - Types and Mounting
1262.01	Guardrail End Delineation
DIVISION 16 - EROSION CONTROL AND ROADSIDE DEVELOPMENT	
1605.01	Temporary Silt Fence
1607.01	Gravel Construction Entrance
1630.06	Special Stilling Basin
1631.01	Matting Installation
1633.01	Temporary Rock Silt Check Type A
1633.02	Temporary Rock Silt Check Type B



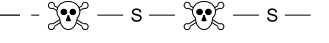
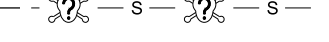







STATE OF NORTH CAROLINA, DIVISION OF HIGHWAYS
CONVENTIONAL PLAN SHEET SYMBOLS

Note: Not to Scale

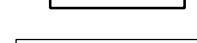

BOUNDARIES AND PROPERTY:

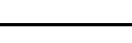
State Line	-----
County Line	-----
Township Line	-----
City Line	-----
Reservation Line	-----
Property Line	-----
Existing Iron Pin (EIP)	
Computed Property Corner	
Existing Concrete Monument (ECM)	
Parcel/Sequence Number	
Existing Fence Line	-x-x-x-x-
Proposed Woven Wire Fence	-----
Proposed Chain Link Fence	-----
Proposed Barbed Wire Fence	-----
Existing Wetland Boundary	---WLB---
Proposed Wetland Boundary	---WLB---
Existing Endangered Animal Boundary	---EAB---
Existing Endangered Plant Boundary	---EPB---
Existing Historic Property Boundary	---HPB---
Known Contamination Area: Soil	 S
Potential Contamination Area: Soil	 S
Known Contamination Area: Water	 W
Potential Contamination Area: Water	 W
Contaminated Site: Known or Potential	

BUILDINGS AND OTHER CULTURE:

Gas Pump Vent or U/G Tank Cap	
Sign	
Well	
Small Mine	
Foundation	
Area Outline	
Cemetery	
Building	
School	
Church	
Dam	



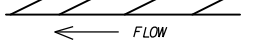
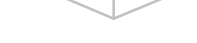









HYDROLOGY:

Stream or Body of Water	-----
Hydro, Pool or Reservoir	
Jurisdictional Stream	---JS---
Buffer Zone 1	---BZ 1---
Buffer Zone 2	---BZ 2---
Flow Arrow	----->
Disappearing Stream	----->
Spring	
Wetland	---WLB---
Proposed Lateral, Tail, Head Ditch	
False Sump	







RAILROADS:

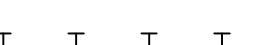
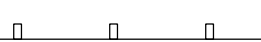
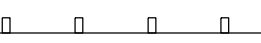

Standard Gauge	-----
RR Signal Milepost	
Switch	
RR Abandoned	-----
RR Dismantled	-----

RIGHT OF WAY & PROJECT CONTROL:



Primary Horiz Control Point	
Primary Horiz and Vert Control Point	
Secondary Horiz and Vert Control Point	
Vertical Benchmark	
Existing Right of Way Monument	
Proposed Right of Way Monument (Rebar and Cap)	
Proposed Right of Way Monument (Concrete)	
Existing Permanent Easement Monument	
Proposed Permanent Easement Monument (Rebar and Cap)	
Existing C/A Monument	
Proposed C/A Monument (Rebar and Cap)	
Proposed C/A Monument (Concrete)	
Existing Right of Way Line	-----
Proposed Right of Way Line	-----
Existing Control of Access Line	-----
Proposed Control of Access Line	-----
Proposed ROW and CA Line	-----
Existing Easement Line	-----
Proposed Temporary Construction Easement	-----
Proposed Temporary Drainage Easement	-----
Proposed Permanent Drainage Easement	-----
Proposed Permanent Drainage/Utility Easement	-----
Proposed Permanent Utility Easement	-----
Proposed Temporary Utility Easement	-----
Proposed Aerial Utility Easement	-----

ROADS AND RELATED FEATURES:

Existing Edge of Pavement	-----
Existing Curb	-----
Proposed Slope Stakes Cut	-----
Proposed Slope Stakes Fill	-----
Proposed Curb Ramp	
Existing Metal Guardrail	
Proposed Guardrail	
Existing Cable Guiderail	
Proposed Cable Guiderail	
Equality Symbol	
Pavement Removal	
VEGETATION:	
Single Tree	
Single Shrub	
Hedge	

Woods Line	-----
Orchard	
Vineyard	

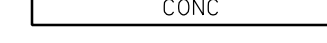
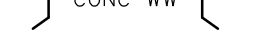
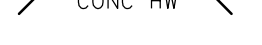
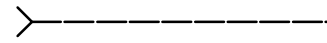







EXISTING STRUCTURES:

MAJOR:	
Bridge, Tunnel or Box Culvert	
Bridge Wing Wall, Head Wall and End Wall	
MINOR:	
Head and End Wall	
Pipe Culvert	-----
Footbridge	
Drainage Box: Catch Basin, DI or JB	
Paved Ditch Gutter	-----
Storm Sewer Manhole	
Storm Sewer	-----





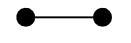

UTILITIES:

* SUE - Subsurface Utility Engineering
LOS - Level of Service - A,B,C or D (Accuracy)



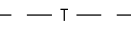

POWER:

Existing Power Pole	
Proposed Power Pole	
Existing Joint Use Pole	
Proposed Joint Use Pole	
Power Manhole	
Power Line Tower	
Power Transformer	
U/G Power Cable Hand Hole	
H-Frame Pole	
U/G Power Line Test Hole (SUE - LOS A)*	
U/G Power Line (SUE - LOS B)*	-----
U/G Power Line (SUE - LOS C)*	-----
U/G Power Line (SUE - LOS D)*	-----





TELEPHONE:

Existing Telephone Pole	
Proposed Telephone Pole	
Telephone Manhole	
Telephone Pedestal	
Telephone Cell Tower	
U/G Telephone Cable Hand Hole	
U/G Telephone Test Hole (SUE - LOS A)*	
U/G Telephone Cable (SUE - LOS B)*	-----
U/G Telephone Cable (SUE - LOS C)*	-----
U/G Telephone Cable (SUE - LOS D)*	-----
U/G Telephone Conduit (SUE - LOS B)*	-----
U/G Telephone Conduit (SUE - LOS C)*	-----
U/G Telephone Conduit (SUE - LOS D)*	-----
U/G Fiber Optics Cable (SUE - LOS B)*	-----
U/G Fiber Optics Cable (SUE - LOS C)*	-----
U/G Fiber Optics Cable (SUE - LOS D)*	-----



WATER:

Water Manhole	
Water Meter	
Water Valve	
Water Hydrant	
U/G Water Line Test Hole (SUE - LOS A)*	
U/G Water Line (SUE - LOS B)*	-----
U/G Water Line (SUE - LOS C)*	-----
U/G Water Line (SUE - LOS D)*	-----
Above Ground Water Line	-----



TV:

TV Pedestal	
TV Tower	
U/G TV Cable Hand Hole	
U/G TV Test Hole (SUE - LOS A)*	
U/G TV Cable (SUE - LOS B)*	-----
U/G TV Cable (SUE - LOS C)*	-----
U/G TV Cable (SUE - LOS D)*	-----
U/G Fiber Optic Cable (SUE - LOS B)*	-----
U/G Fiber Optic Cable (SUE - LOS C)*	-----
U/G Fiber Optic Cable (SUE - LOS D)*	-----











GAS:

Gas Valve	
Gas Meter	
U/G Gas Line Test Hole (SUE - LOS A)*	
U/G Gas Line (SUE - LOS B)*	-----
U/G Gas Line (SUE - LOS C)*	-----
U/G Gas Line (SUE - LOS D)*	-----
Above Ground Gas Line	-----

SANITARY SEWER:

Sanitary Sewer Manhole	
Sanitary Sewer Cleanout	
U/G Sanitary Sewer Line	-----
Above Ground Sanitary Sewer	-----
SS Force Main Line Test Hole (SUE - LOS A)*	
SS Force Main Line (SUE - LOS B)*	-----
SS Force Main Line (SUE - LOS C)*	-----
SS Force Main Line (SUE - LOS D)*	-----

MISCELLANEOUS:

Utility Pole	
Utility Pole with Base	
Utility Located Object	
Utility Traffic Signal Box	
Utility Unknown U/G Line (SUE - LOS B)*	-----
U/G Tank; Water, Gas, Oil	
Underground Storage Tank, Approx. Loc.	
A/G Tank; Water, Gas, Oil	
Geoenvironmental Boring	
Abandoned According to Utility Records	
End of Information	

9/10/2021
12/29/2023
I:\Projects\4017927\4017927_000\150_Deliverables & Submittals\78P\4.R\6.L\Brdge_244\Roadway\Prj\SH\TV\78P\4R\6L\rdy_psh01B.dgn
owensc

PROJECT REFERENCE NO. <i>B-6025</i>	SHEET NO. <i>2A-1</i>
ROADWAY DESIGN ENGINEER	PAVEMENT DESIGN ENGINEER
DOCUMENT NOT CONSIDERED FINAL UNLESS ALL SIGNATURES COMPLETED	
STV Engineers, Inc. 900 West Trade St., Suite 715 Charlotte, NC 28202 NC License Number F-0991	

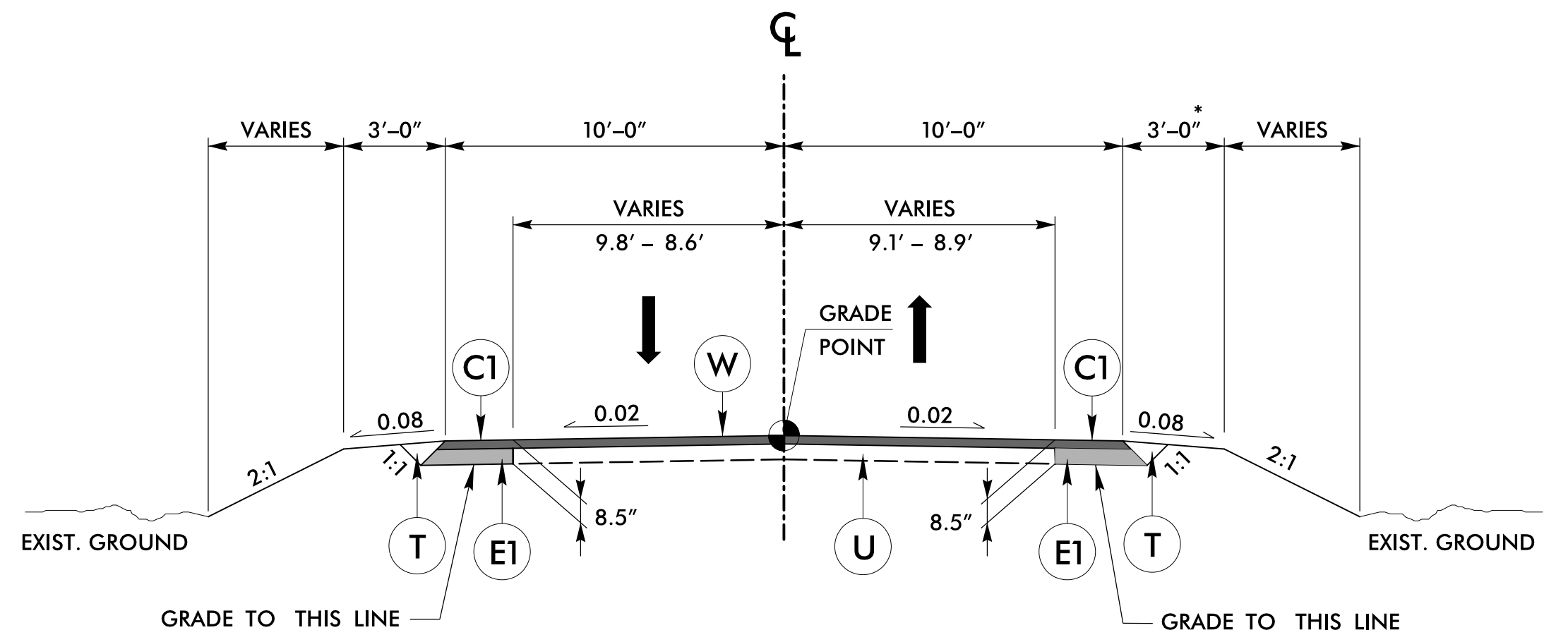

TYPICAL SECTION 1
 -L- STA. 11+70.00 TO 12+25.00
 -L- STA. 14+60.00 TO 15+50.00
 * 7'-0" WITH GUARDRAIL

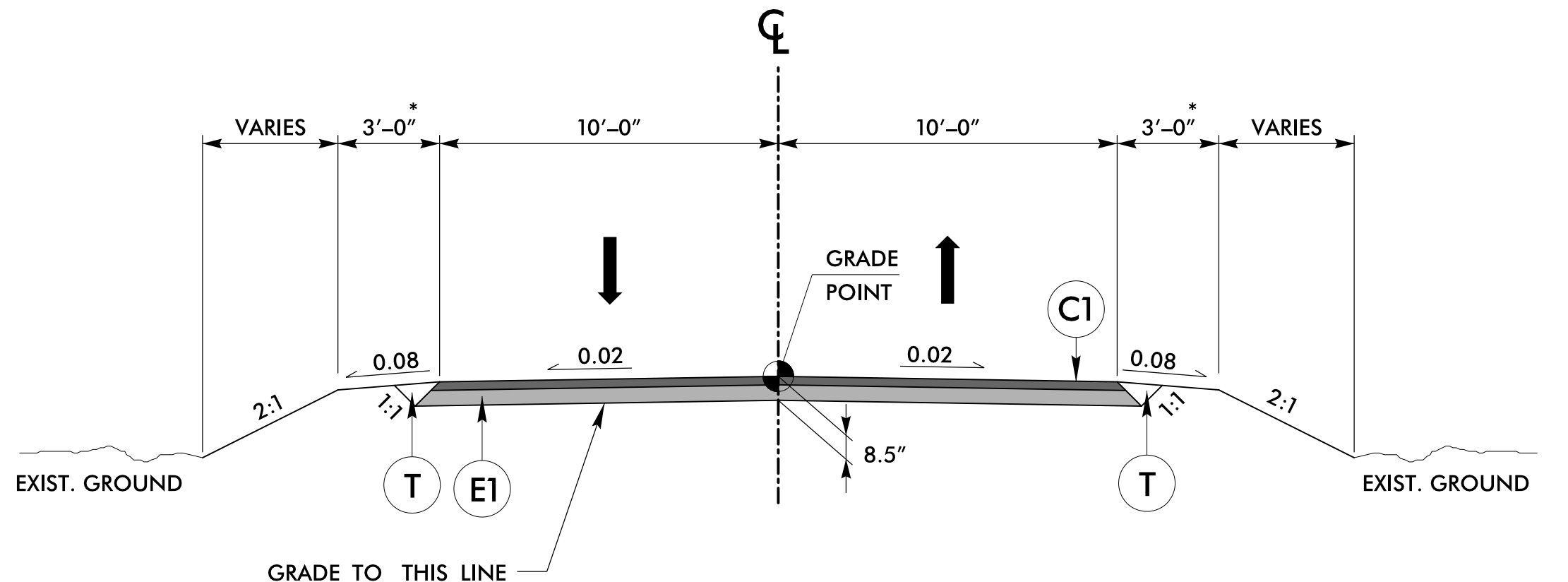

TYPICAL SECTION 2
 -L- STA. 12+25.00 TO 13+86.42 (BEGIN CULVERT)
 -L- STA. 14+15.58 (END CULVERT) TO 14+60.00
 * 7'-0" WITH GUARDRAIL

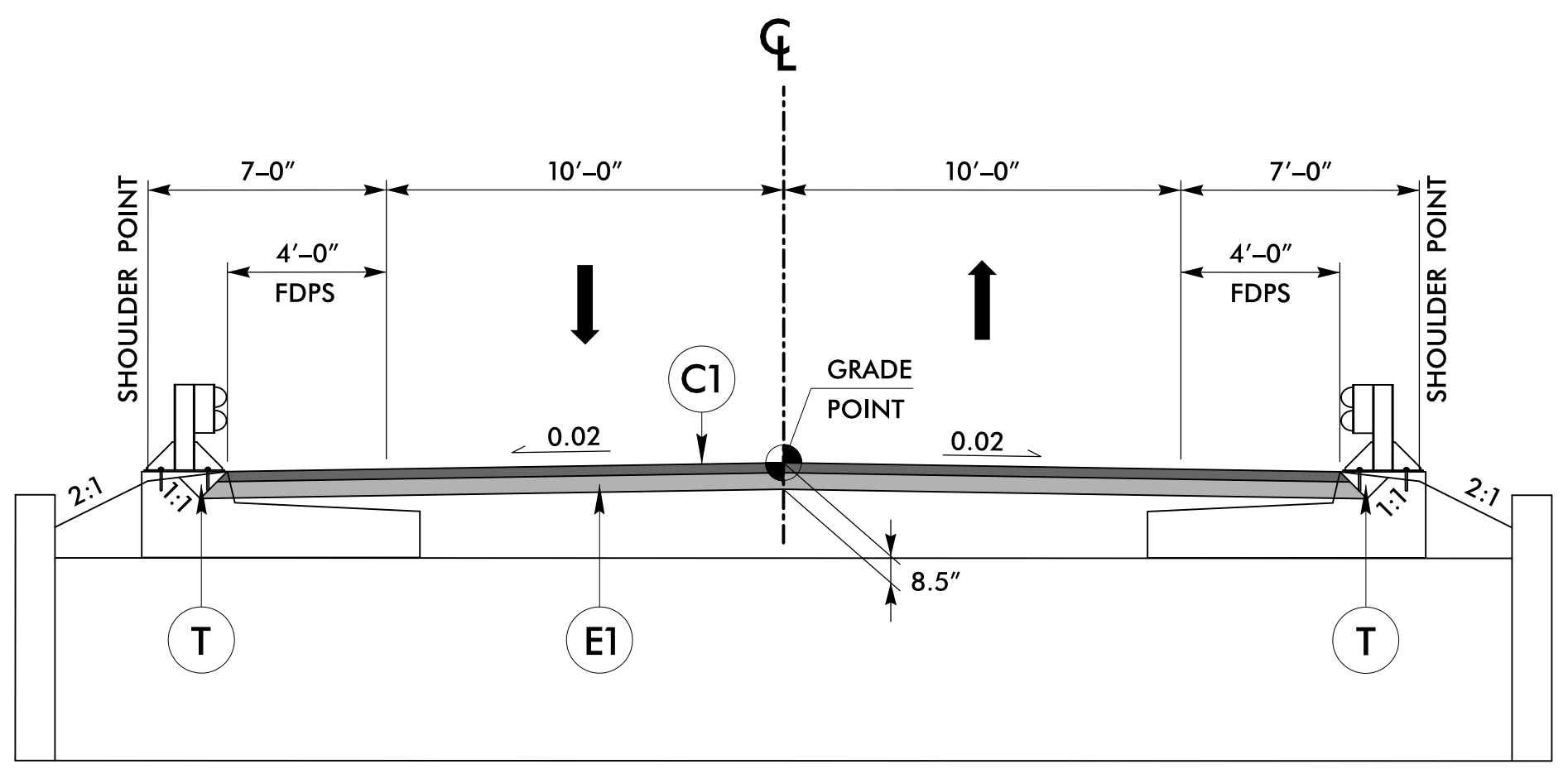

TYPICAL SECTION 3
 -L- STA. 13+86.42 (BEGIN CULVERT) TO 14+15.58 (END CULVERT)

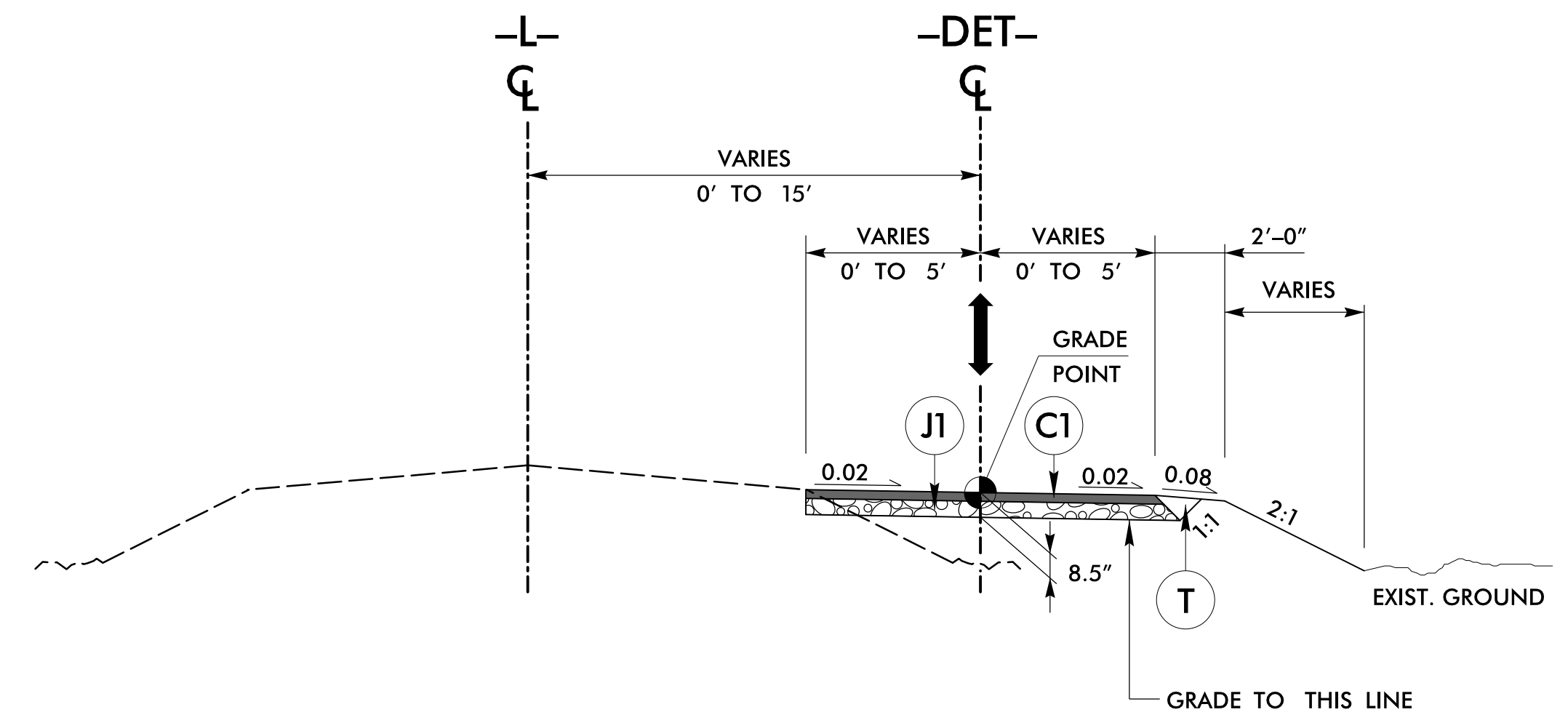

TYPICAL SECTION 4
 -DET- STA. 11+46.85 TO 12+72.07
 -DET- STA. 15+83.03 TO 16+22.59

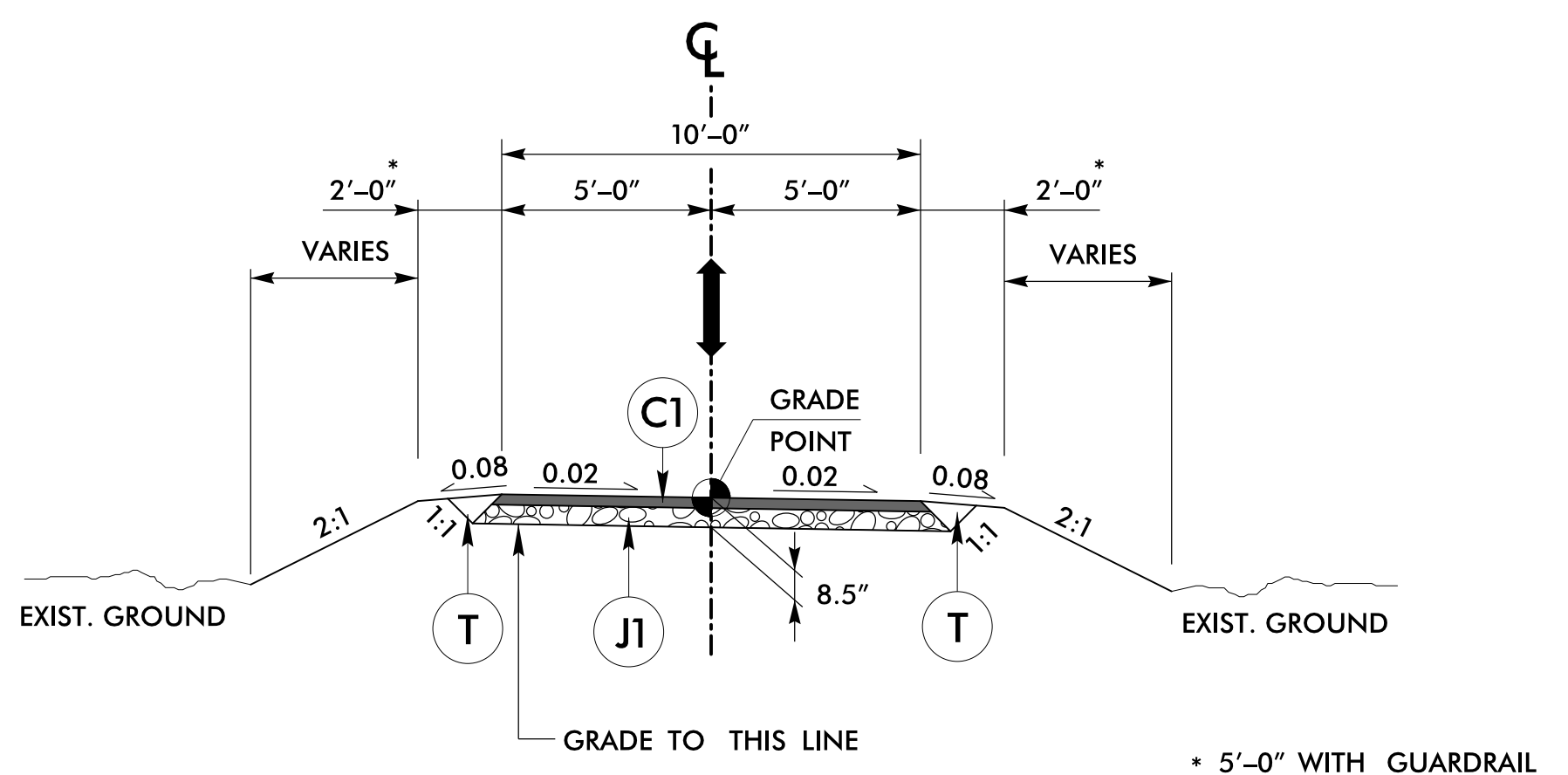

TYPICAL SECTION 5
 -DET- STA. 12+72.07 TO 15+83.03
 * 5'-0" WITH GUARDRAIL

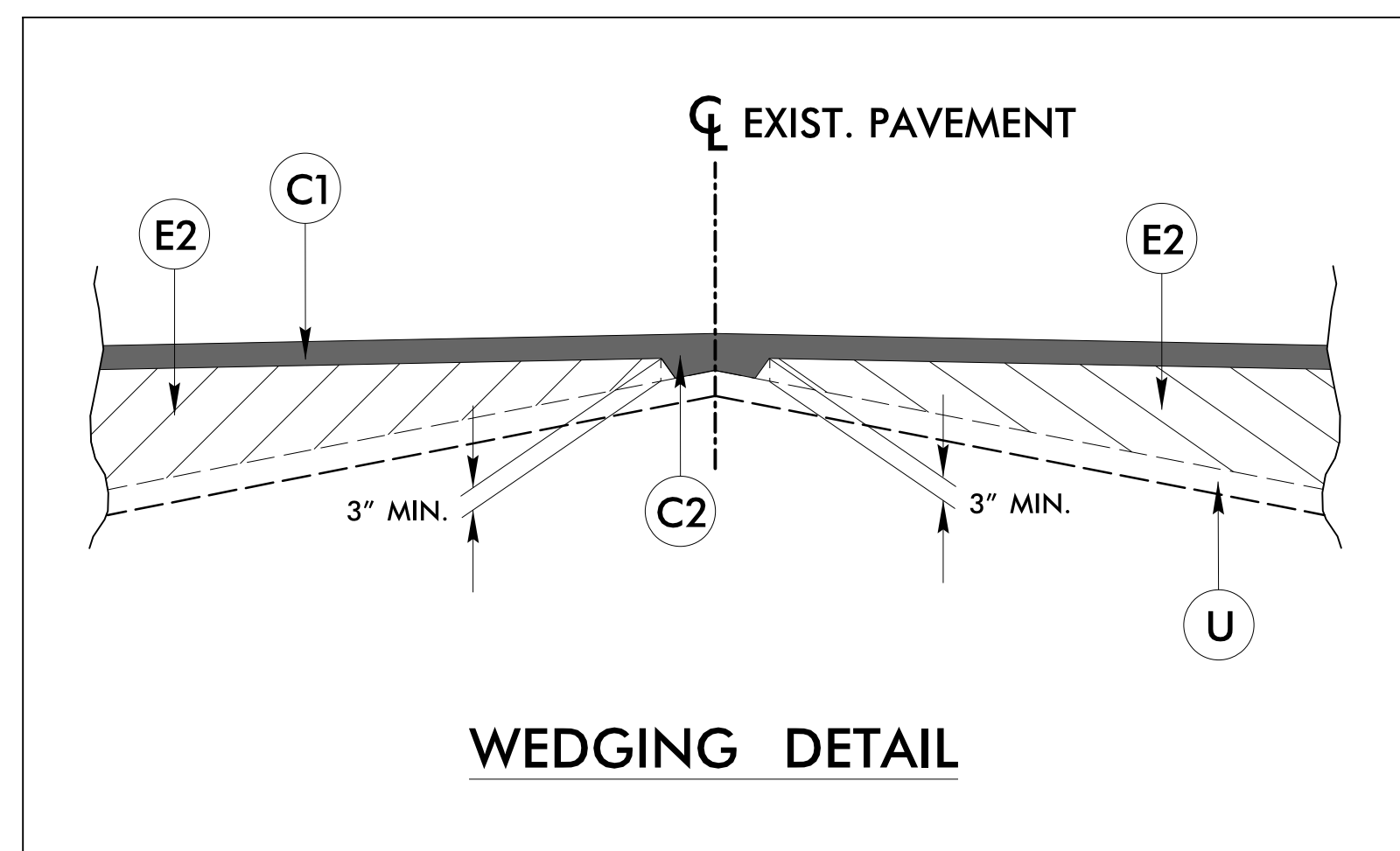

WEDGING DETAIL

PAVEMENT SCHEDULE	
C1	PROP. APPROX. 3" ASPHALT CONCRETE SURFACE COURSE, TYPE S9.5C, AT AN AVERAGE RATE OF 168 LBS. PER SQ. YD. IN EACH OF TWO LAYERS.
C2	PROP. VAR. DEPTH ASPHALT CONCRETE SURFACE COURSE, TYPE S9.5C, AT AN AVERAGE RATE OF 112 LBS. PER SQ. YD. PER 1" DEPTH. TO BE PLACED IN LAYERS NOT TO EXCEED 1.5" IN DEPTH.
E1	PROP. APPROX. 5.5" ASPHALT CONCRETE BASE COURSE, TYPE B25.0C, AT AN AVERAGE RATE OF 627 LBS. PER SQ. YD.
E2	PROP. VAR. DEPTH ASPHALT CONCRETE BASE COURSE, TYPE B25.0C, AT AN AVERAGE RATE OF 114 LBS. PER SQ. YD. PER 1" DEPTH. TO BE PLACED IN LAYERS NOT LESS THAN 3.0" IN DEPTH OR GREATER THAN 5.5" IN DEPTH.
J1	PROP. 5.5" AGGREGATE BASE COURSE
T	EARTH MATERIAL
U	EXISTING PAVEMENT
W	PAVEMENT WEDGING

ALL PAVEMENT SLOPES ARE 1:1 UNLESS SHOWN OTHERWISE.

12/29/2023
 R:\Roadway\Proj\SHHT\7BP4R161_rdy_psh02A-L.txd.dgn
 Owens

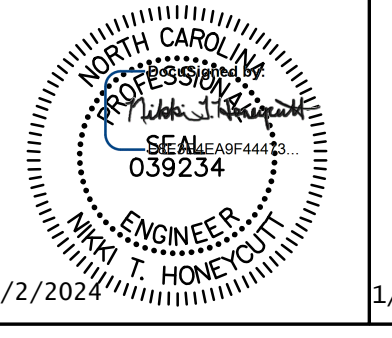
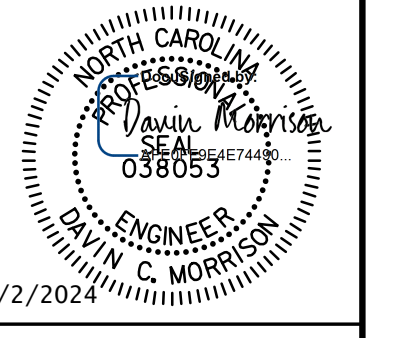
PROJECT REFERENCE NO. B-6025	SHEET NO. 2B-1
ROADWAY DESIGN ENGINEER 	HYDRAULICS ENGINEER 
DOCUMENT NOT CONSIDERED FINAL UNLESS ALL SIGNATURES COMPLETED	

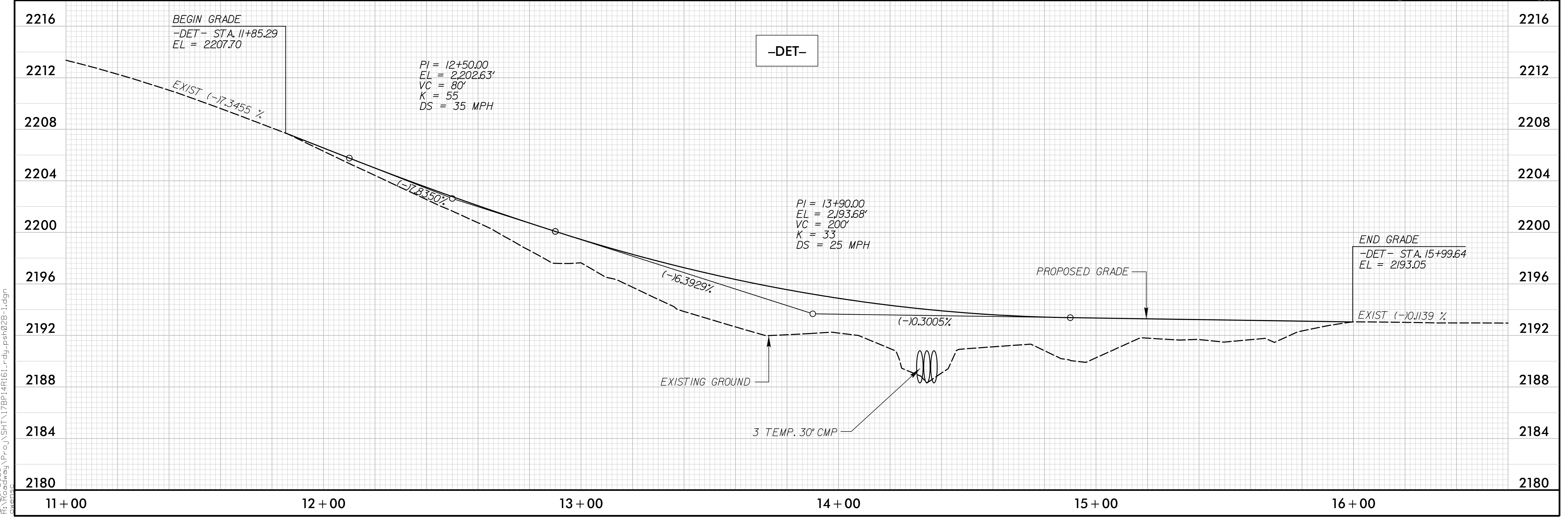
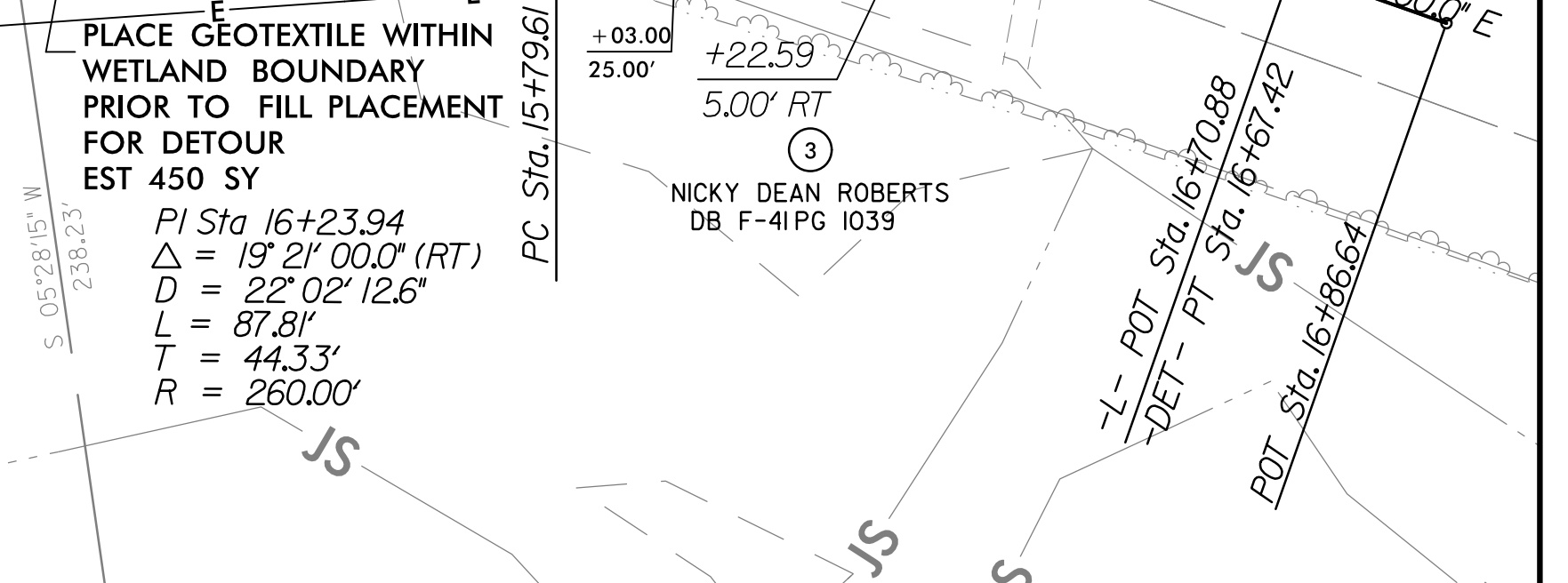
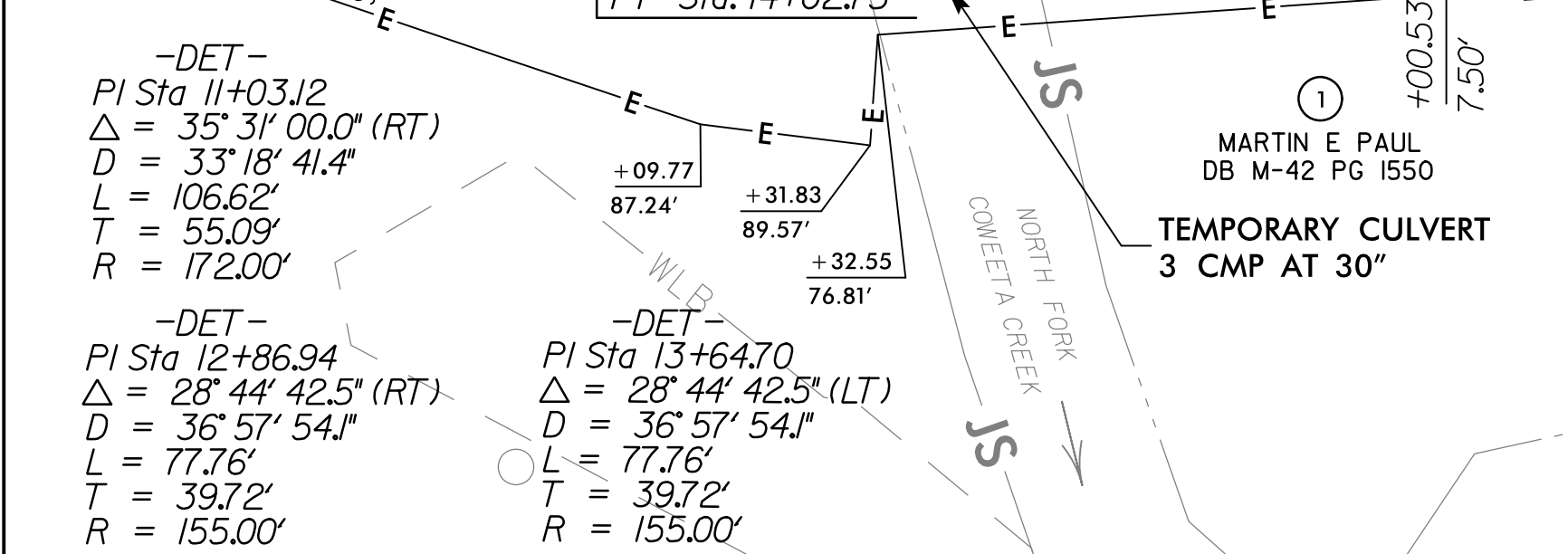
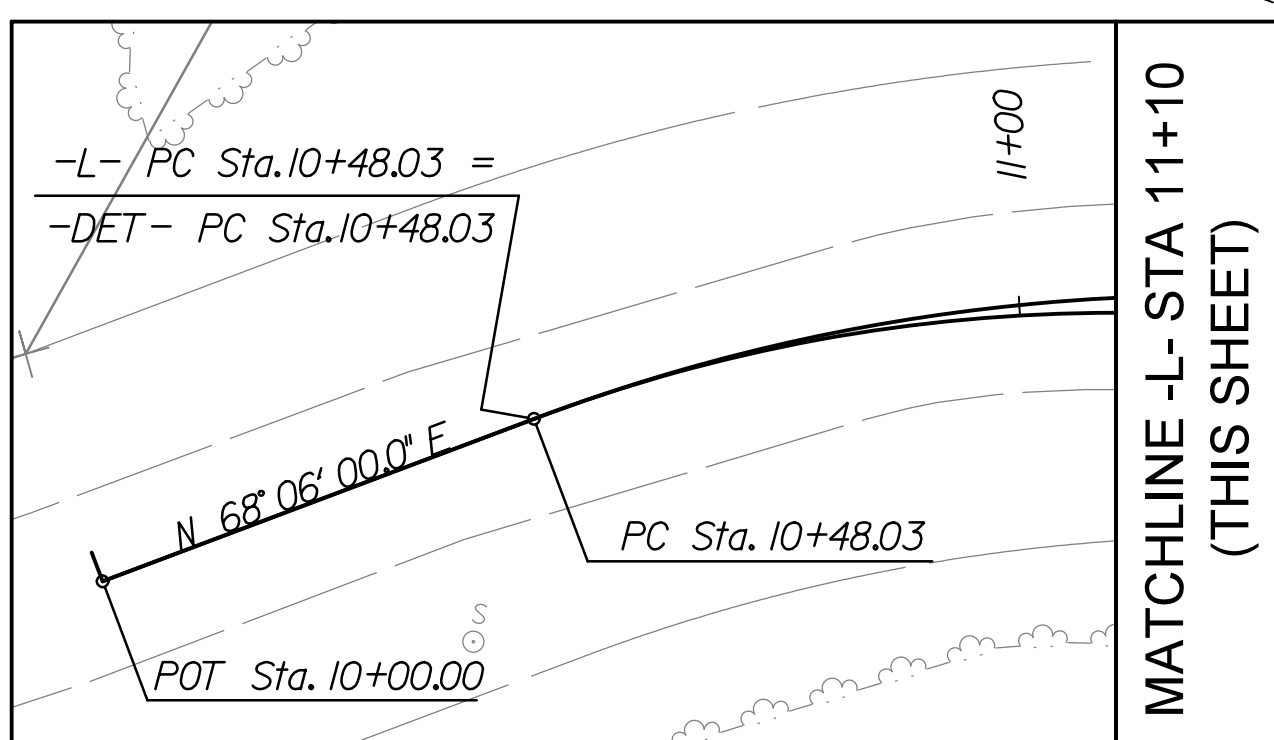
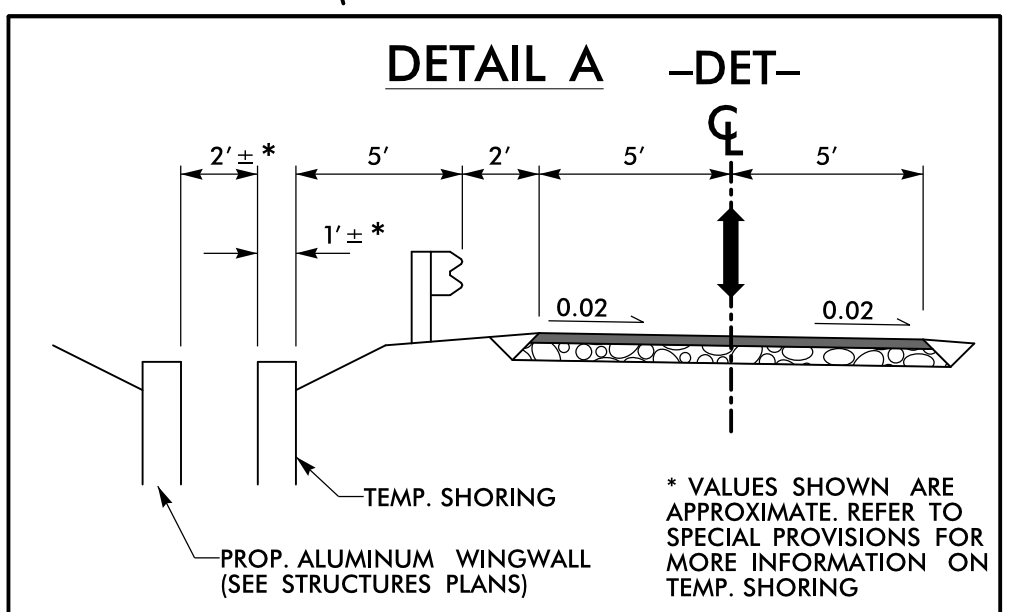
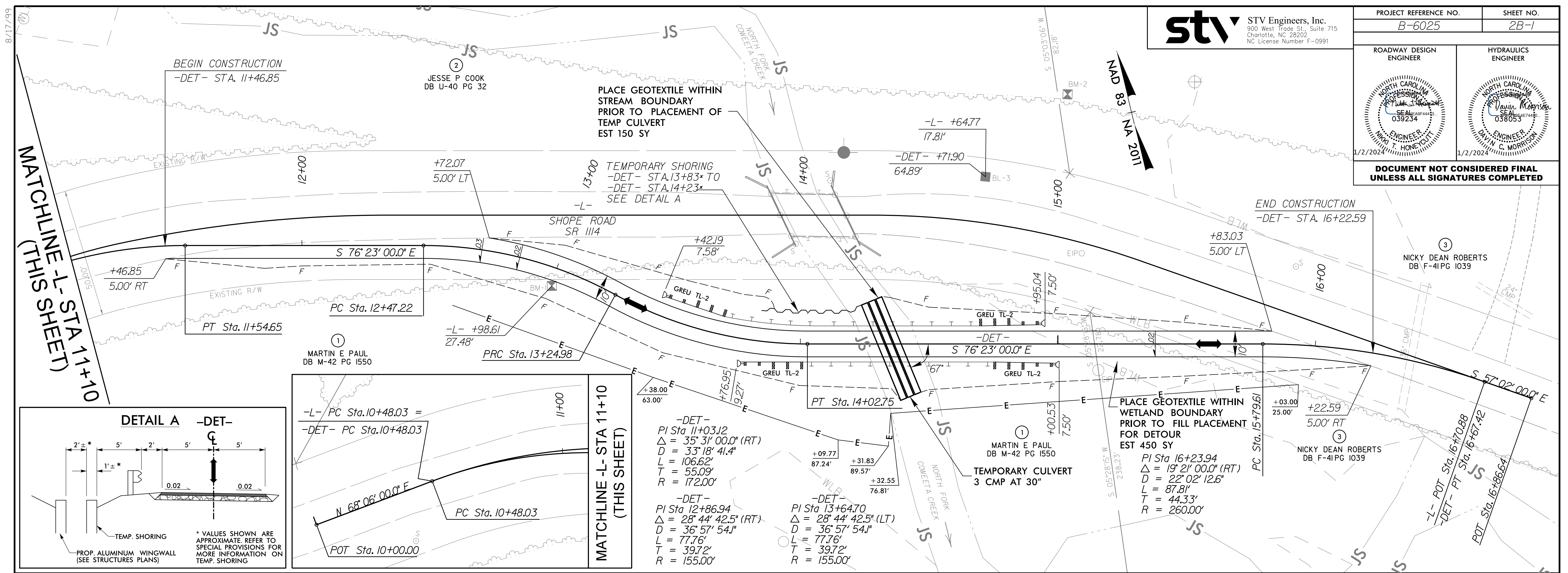

12/29/2023
 R:\Projects\2023\Projects\SHIT\178P14R161_r.dwg_psh02B-1.dgn
 OVERSEER

DIVISION OF HIGHWAYS STATE OF NORTH CAROLINA

STV Engineers, Inc. <small>900 West Trade St., Suite 715 Charlotte, NC 28202 NC License Number F-0991</small>	PROJECT REFERENCE NO.	SHEET NO.
	B-6025	3B-1

EARTHWORK SUMMARY (IN CUBIC YARDS)

CHAIN	FROM STATION	TO STATION	SIDE	PHASE	UNCL. EXCAVATION	UNDERCUT	EMBT + %	BORROW
-DET-	11+46.85	16+22.59	LT & RT	I	7		659	652
-L-	11+70.00	15+50.00	LT & RT	II	4		1,262	1,258
TOTAL					11		1,921	1,910
WASTE IN LIEU OF BORROW								
PROJECT TOTAL					11		1,921	1,910
								95
GRAND TOTAL					11		1,921	2,005
SAY								2,020

PAVEMENT REMOVAL SUMMARY

SURVEY LINE	STATION	STATION	LOCATION LT/RT/CL	YD ²
-L-	12+25	14+60	CL	400
-DET-	11+47	16+23	RT	490
TOTAL:				890
SAY:				890

NOTE: Approximate quantities only. Unclassified Excavation, Borrow Excavation, Fine Grading, Clearing and Grubbing, and Removal of Existing Pavement will be paid for at the contract lump sum price for "Grading."

* W = MEASURED FROM "N" AT THE BEGINNING OF THE ANCHOR TO "N" AT THE END OF THE ANCHOR.
 "N" = DISTANCE FROM EDGE OF LANE TO FACE OF GUARDRAIL
 TOTAL SHOULDER WIDTH = DISTANCE FROM EDGE OF TRAVEL LANE TO SHOULDER BREAK POINT.
 FLARE LENGTH = DISTANCE FROM LAST SECTION OF PARALLEL GUARDRAIL TO END OF GUARDRAIL.
 W = TOTAL WIDTH OF FLARE FROM BEGINNING OF TAPER TO END OF GUARDRAIL.
 G = GATING IMPACT ATTENUATOR TYPE 350
 NG = NON-GATING IMPACT ATTENUATOR TYPE 350

GUARDRAIL SUMMARY

SURVEY LINE	BEG. STA.	END STA.	LOCATION	LENGTH			WARRANT POINT		"N" DIST. FROM E.O.L.	TOTAL SHOUL. WIDTH	FLARE LENGTH		W*		ANCHORS								IMPACT ATTENUATOR TYPE 350			SINGLE FACED GUARDRAIL	REMOVE EXISTING GUARDRAIL	REMOVE AND STOCKPILE EXISTING GUARDRAIL	REMARKS			
				STRAIGHT	SHOP CURVED	DOUBLE FACED	APPROACH END	TRAILING END			APPROACH END	TRAILING END	APPROACH END	TRAILING END	XI MOD	B-77	GREU TL-2	M-350	TYPE III	CAT-1	VI MOD	BIC	AT-1	EA	G					NG		
-L-	13+21.17	14+57.13	LT	137.50			14+07.50	13+78.34	4	7	25	25	0.5	0.5																		
-L-	13+37.34	14+76.99	RT	137.50			13+94.50	14+23.69	4	7	25	25	0.5	0.5																		
TOTAL:				275.00																												
TOTAL ANCHOR LENGTH:				100.00																												
TOTAL GUARDRAIL LENGTH:				175.00																												
SAY:				180.00 LF			ADD. GUARDRAIL POSTS:		5 EA																							

TEMPORARY GUARDRAIL SUMMARY

SURVEY LINE	BEG. STA.	END STA.	LOCATION	LENGTH			WARRANT POINT		"N" DIST. FROM E.O.L.	TOTAL SHOUL. WIDTH	FLARE LENGTH		W*		ANCHORS								IMPACT ATTENUATOR TYPE 350			SINGLE FACED GUARDRAIL	REMOVE EXISTING GUARDRAIL	REMOVE AND STOCKPILE EXISTING GUARDRAIL	REMARKS				
				STRAIGHT	SHOP CURVED	DOUBLE FACED	APPROACH END	TRAILING END			APPROACH END	TRAILING END	APPROACH END	TRAILING END	XI MOD	B-77	GREU TL-2	M-350	TYPE III	CAT-1	VI MOD	BIC	AT-1	EA	G					NG			
-DET-	13+42.19	14+95.04	LT	150.00			14+35.46	14+27.89	2	5	25	25	0.5	0.5																			
-DET-	13+76.95	15+00.53	RT	125.00			14+33.65	14+40.40	2	5	25	25	0.5	0.5																			
TOTAL:				275.00																													
TOTAL ANCHOR LENGTH:				100.00																													
TOTAL GUARDRAIL LENGTH:				175.00																													
SAY:				180.00 LF			ADD. GUARDRAIL POSTS:		5 EA																								

12/29/2023 11:41:17 AM R:\Roadway\Proj\SH\T\TBP\4R161_f.dwg_psh03B-L.dgn owensc

6/2/99

STATE OF NORTH CAROLINA DIVISION OF HIGHWAYS

PROJECT REFERENCE NO. <i>B-6025</i>	SHEET NO. <i>3P-1</i>
 STV Engineers, Inc. <small>900 West Trade St., Suite 715 Charlotte, NC 28202 NC License Number F-0991</small>	

PARCEL INDEX SHEET

PARCEL NO.	SHEET NO.	PROPERTY OWNER NAME	AREA TAKEN		
			ROW (SF)	TCE (SF)	PUE (SF)
1	4	MARTIN E PAUL	2903	7391	-
2	4	JESSE P COOK	4850	-	5074
3	4	NICKY DEAN ROBERTS	-	1298	1054

STV Engineers, Inc.
900 West Trade St., Suite 715
Charlotte, NC 28202
NC License Number F-0991

PROJECT REFERENCE NO. B-6025	SHEET NO. 4
--	-----------------------

ROADWAY DESIGN ENGINEER

JESSE P. COOK
DB U-40 PG 32
1/2/2024

HYDRAULICS ENGINEER

NICKY DEAN ROBERTS
DB F-41 PG 1039
1/2/2024

DOCUMENT NOT CONSIDERED FINAL
UNLESS ALL SIGNATURES COMPLETED

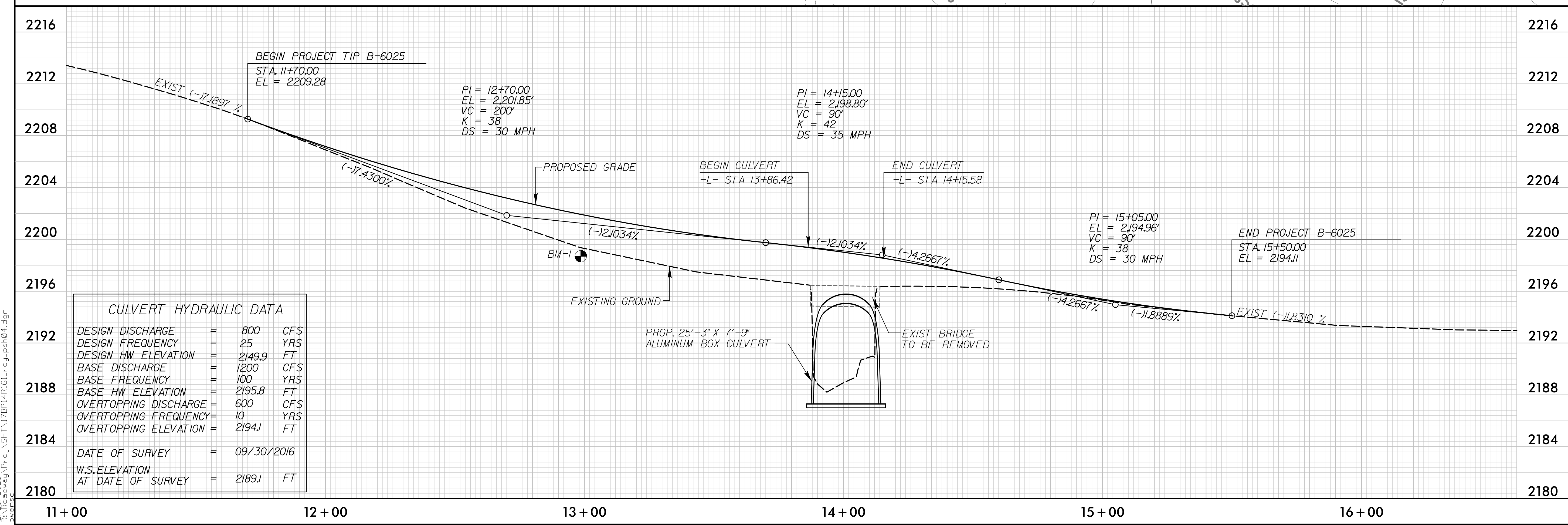
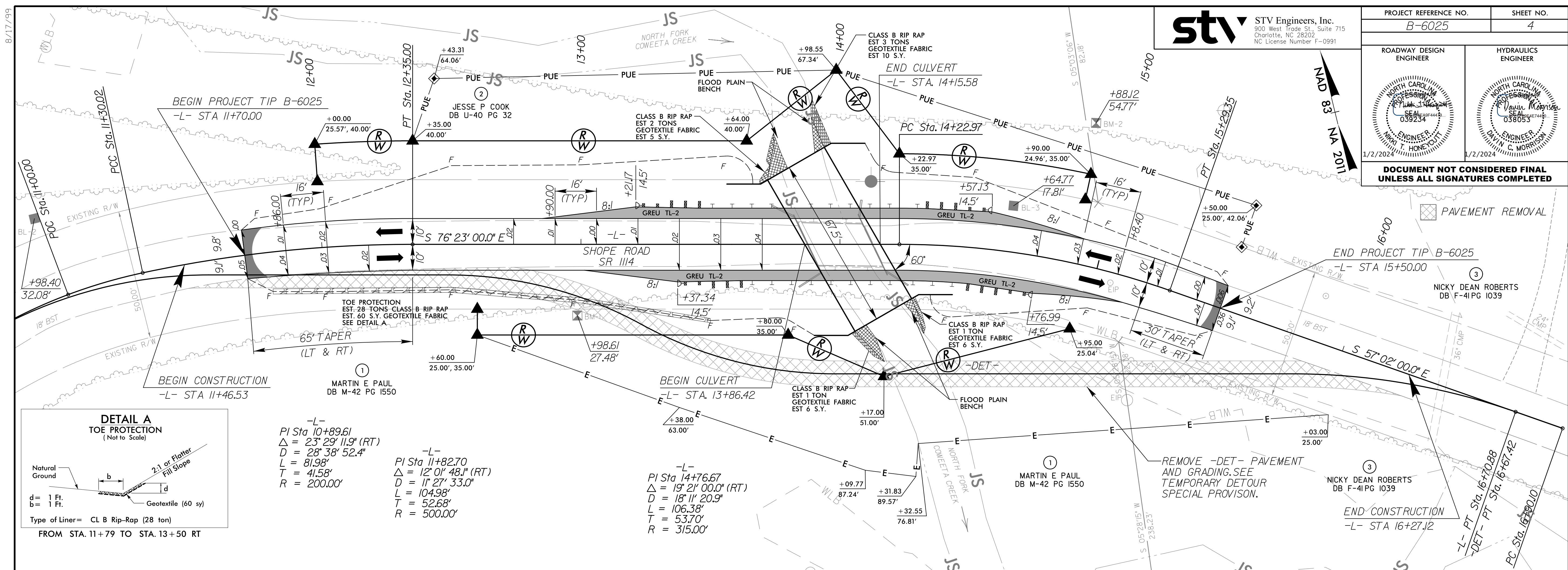

8/17/199

I:\2023\Projects\SHOPE\178P14R161_r.dwg

TIP PROJECT: B-6025

STATE OF NORTH CAROLINA
DIVISION OF HIGHWAYS

STATE	STATE PROJECT REFERENCE NO.	SHEET NO.	TOTAL SHEETS
N.C.	B-6025	RW01	

SURVEY CONTROL, EXISTING CENTERLINES,
RIGHT OF WAY, EASEMENTS AND PROPERTY TIES

MACON COUNTY

LOCATION: BRIDGE #244 OVER NORTH FORK COWEETA CREEK
ON SR 1114 (SHOPE RD)

TYPE OF WORK: GRADING, PAVING, DRAINAGE, & STRUCTURE

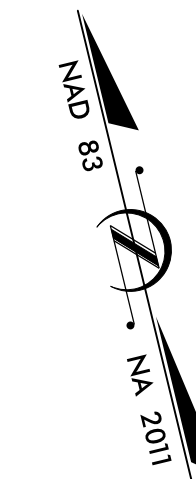
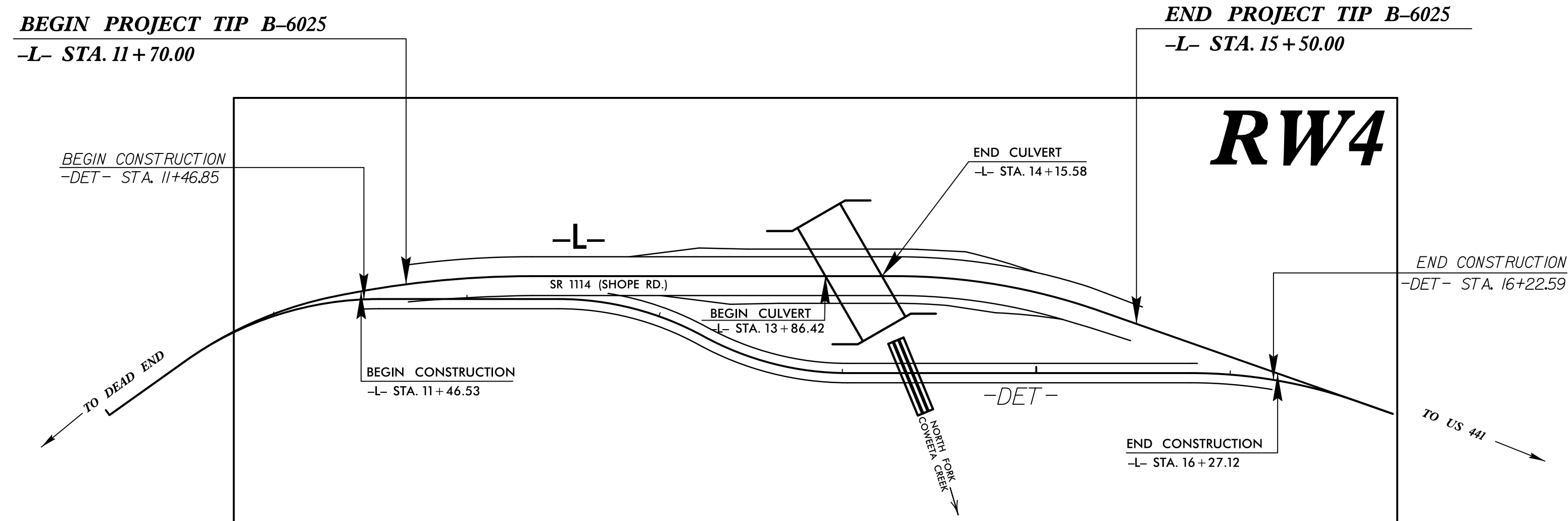

GRAPHIC SCALE

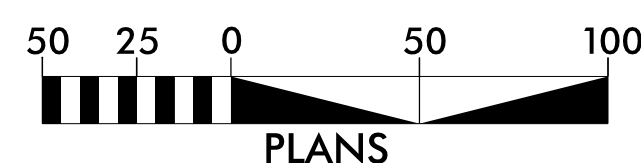

DATUM DESCRIPTION

THE LOCALIZED COORDINATE SYSTEM DEVELOPED FOR THIS PROJECT IS BASED ON THE STATE PLANE COORDINATES ESTABLISHED BY NCDOT FOR MONUMENT "GPS-101" WITH NAD 83/NA 2011 STATE PLANE GRID COORDINATES OF NORTHING: 510,257.351(ft) EASTING: 680342.647(ft) ELEVATION: 2162.96(ft)

THE AVERAGE COMBINED GRID FACTOR USED ON THIS PROJECT (GROUND TO GRID) IS: .99977869545

THE N.C. LAMBERT GRID BEARING AND LOCALIZED HORIZONTAL GROUND DISTANCE FROM "GPS-101" TO -L- STATION 11+70.00 IS N 69°23'.08"W 1879.92(ft)

ALL LINEAR DIMENSIONS ARE LOCALIZED HORIZONTAL DISTANCES VERTICAL DATUM USED IS NAVD 88

Prepared In the Office of:
DIVISION OF HIGHWAYS
1000 Birch Ridge Dr., Raleigh NC, 27610

2024 STANDARD SPECIFICATIONS

RIGHT OF WAY DATE:
NOVEMBER 30, 2017

LETTING DATE:
APRIL 9, 2024

PROFESSIONAL LAND SURVEYOR



DocuSigned by:
Brian Barwatt 2/8/2024
SIGNATURE: DATE:

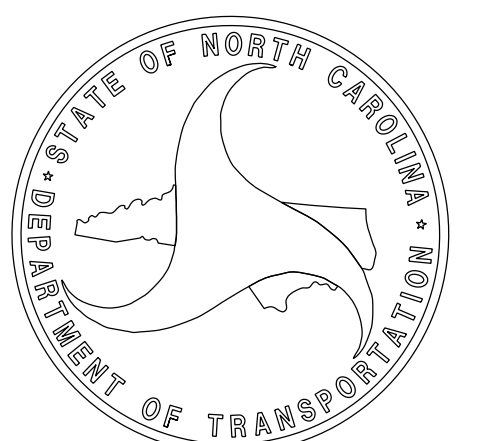

PROJECT REFERENCE NO.	SHEET NO.
B-6025	RW02C-1
Location and Surveys	

SURVEY CONTROL SHEET

W/EXISTING CENTERLINE ALIGNMENTS PRIOR TO CONSTRUCTION

SEE SHEET RW02C-3
FOR FURTHER
ALIGNMENT DETAILS

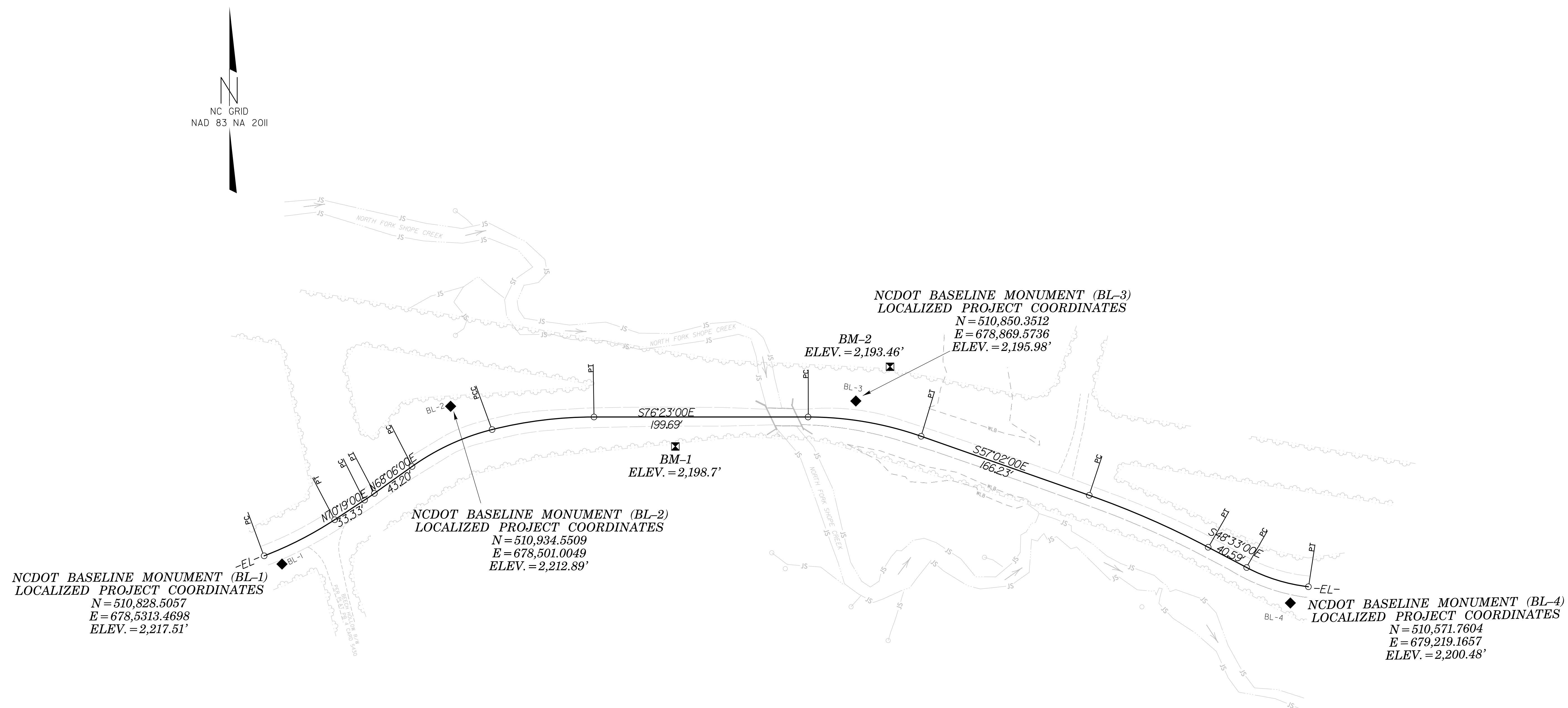

NOTES:

1. PROJECT CONTROL WAS ESTABLISHED USING GNSS, THE GLOBAL NAVIGATION SATELLITE SYSTEM.
2. THE SURVEY CONTROL DATA FOR THIS PROJECT HAS BEEN COMPILED FROM VARIOUS SOURCES. IF FURTHER INFORMATION REGARDING PROJECT CONTROL IS NEEDED, PLEASE CONTACT THE LOCATION AND SURVEYS UNIT.

6/22/99

PROJECT REFERENCE NO.	SHEET NO.
B-6025	RW02C-2
Location and Surveys	

SURVEY CONTROL SHEET

W/EXISTING CENTERLINE ALIGNMENTS PRIOR TO CONSTRUCTION

BL	POINT	DESC.	NORTH	EAST	ELEVATION
	1	BL-1	510828.5057	678313.4698	2217.51
	2	BL-2	510934.5509	678501.0049	2212.89
	3	BL-3	510850.3512	678869.5736	2195.98
	4	BL-4	510571.7604	679219.1657	2200.48

 BM1 ELEVATION = 2198.69
 N 510849 E 678696
 8" SPIKE IN BASE OF 10" POPLAR

 BM2 ELEVATION = 2193.46
 N 510874 E 678908
 8" SPIKE IN BASE OF 20" MAPLE

NOTES:

1. PROJECT CONTROL WAS ESTABLISHED USING GNSS, THE GLOBAL NAVIGATION SATELLITE SYSTEM.
2. THE SURVEY CONTROL DATA FOR THIS PROJECT HAS BEEN COMPILED FROM VARIOUS SOURCES. IF FURTHER INFORMATION REGARDING PROJECT CONTROL IS NEEDED, PLEASE CONTACT THE LOCATION AND SURVEYS UNIT.

P:\2023\Roadway\Proj\Survey Control\550244_1s-rw02c-2.dgn

SURVEY CONTROL SHEET

W/EXISTING CENTERLINE ALIGNMENTS PRIOR TO CONSTRUCTION

EL POINT	N	E	BEARING	DIST	DELTA	D	L	T	R
PC	510839.947	678299.096							
CURVE			N 76°29'10.4" E	73.95	12°20'20.9"(LT)	16°39'14.6"	74.09	37.19	344.04
PT	510857.227	678370.996							
LINE			N 70°19'00.0" E	33.33					
PC	510868.455	678402.383							
CURVE			N 69°12'30.0" E	11.08	02°13'00.0"(LT)	20°00'00.0"	11.08	5.54	286.48
PT	510872.389	678412.744							
LINE			N 68°06'00.0" E	43.20					
PC	510888.502	678452.827							
CURVE			N 78°50'31.5" E	82.20	21°29'02.9"(RT)	25°58'57.5"	82.69	41.83	220.52
PCC	510904.409	678533.476							
CURVE			S 83°23'58.5" E	95.80	14°01'57.1"(RT)	14°36'42.0"	96.04	48.26	392.12
PT	510893.398	678628.637							
LINE			S 76°23'00.0" E	199.69					
PC	510846.385	678822.718							
CURVE			S 66°42'30.0" E	106.99	19°21'00.0"(RT)	18°00'00.0"	107.50	54.27	318.31
PT	510804.080	678920.988							
LINE			S 57°02'00.0" E	166.23					
PC	510713.626	679060.453							
CURVE			S 52°47'30.0" E	121.08	08°29'00.0"(RT)	07°00'00.0"	121.19	60.71	818.51
PT	510640.408	679156.886							
LINE			S 48°33'00.0" E	40.59					
PC	510613.540	679187.307							
CURVE			S 59°05'45.5" E	60.32	21°05'30.9"(LT)	34°46'14.6"	60.66	30.68	164.78
PT	510613.540	679187.307							

NOTES:

1. PROJECT CONTROL WAS ESTABLISHED USING GNSS, THE GLOBAL NAVIGATION SATELLITE SYSTEM.
2. THE SURVEY CONTROL DATA FOR THIS PROJECT HAS BEEN COMPILED FROM VARIOUS SOURCES. IF FURTHER INFORMATION REGARDING PROJECT CONTROL IS NEEDED, PLEASE CONTACT THE LOCATION AND SURVEYS UNIT.

PROPOSED ALIGNMENT CONTROL SHEET

L

TYPE	STATION	NORTH	EAST
POT	10+00.00	510872.0943	678412.0112
PC	10+48.03	510890.0105	678456.5792
PCC	11+30.02	510904.3666	678536.7145
PT	12+35.00	510890.5046	678640.5826
PC	14+22.97	510846.2525	678823.2661
PT	15+29.35	510804.3874	678920.5148
PC	16+90.10	510716.9152	679055.3819
PT	18+23.35	510636.4069	679161.4156
POT	18+60.00	510612.1489	679188.8825

DET

TYPE	STATION	NORTH	EAST
POT	10+00.00	510872.0943	678412.0112
PC	10+48.03	510890.0105	678456.5792
PT	11+54.65	510897.5882	678561.2262
PC	12+47.22	510875.7955	678651.1918
PRC	13+24.98	510839.6824	678719.1415
PT	14+02.75	510803.5693	678787.0912
PC	15+79.61	510761.9308	678958.9852
PT	16+67.42	510727.3754	679039.2540
POT	16+86.64	510716.9152	679055.3819

NOTES:

1. PROJECT CONTROL WAS ESTABLISHED USING GNSS, THE GLOBAL NAVIGATION SATELLITE SYSTEM.
2. THE PROPOSED ALIGNMENT CONTROL DATA FOR THIS PROJECT HAS BEEN COMPILED FROM VARIOUS SOURCES. IF FURTHER INFORMATINO REGARDING PROJECT CONTROL IS NEEDED, PLEASE CONTACT THE LOCATION AND SURVEYS UNIT.

RIGHT OF WAY CONTROL SHEET

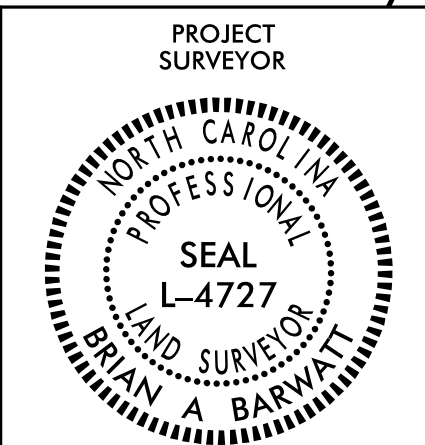
PROJECT REFERENCE NO.	SHEET NO.
B-6025	RW03E-1
Location and Surveys	
	

I, Brian Barwatt, a Professional Land Surveyor in the state of North Carolina hereby certify to the best of my knowledge and belief that the following work item(s) (Base map Compilation, R/W Staking) performed under my responsible charge meet NCDOT Survey Standards as directed in the NCDOT Location & Surveys guidelines and procedures.

I further certify that the data compiled came from available surveys/mapping performed by others and provided to me by NCDOT and do not certify to the accuracy or quality of the individual data sources.

I further certify that the right of way and permanent easement points shown herein and outlined in the tables shown hereon (localized coordinates, station/offset) have been checked and are accurate representations of the right of way and permanent easement points depicted on the corresponding highway plans. I also certify that the right of way and permanent easement points shown herein have been field monumented under my supervision from existing survey control provided by others; that the depicted property data shown herein were surveyed by others; and these monuments denote the right of way and easement boundaries at the time of staking which may be subject to change due to right of way revisions (See deeds for final determination).

Witness my original signature, registration number and seal this 2nd day of January, 2024.

DocuSigned by:

 L-4727
 Professional Land Surveyor PLS # Seal

**DOCUMENT NOT CONSIDERED FINAL
UNLESS ALL SIGNATURES COMPLETED**

ROW MARKER IRON PIN AND CAP - E

ALIGN	STATION	OFFSET	NORTH	EAST
L	12+00.00	-25.57	510922.7579	678610.5726
L	12+00.00	-40.00	510936.9868	678612.9807
L	12+35.00	-40.00	510929.3803	678649.9996
L	13+64.00	-40.00	510899.0105	678775.3737
L	13+98.55	-67.34	510917.4464	678815.3893
L	14+22.97	-35.00	510880.2688	678831.5060
L	14+90.00	-35.00	510855.1928	678901.4901
L	14+90.00	-24.96	510846.1503	678897.1169
L	14+95.00	25.04	510799.1037	678879.4764
L	14+17.00	51.00	510798.0907	678805.4604
L	13+80.00	35.00	510822.3517	678773.2672
L	12+60.00	35.00	510850.6027	678656.6401
L	12+60.00	25.00	510860.3216	678658.9943

ROW MARKER PERMANENT EASEMENT - E

ALIGN	STATION	OFFSET	NORTH	EAST
L	12+43.31	-64.06	510950.8105	678663.7366
L	15+50.00	-42.06	510828.4388	678960.7284
L	15+50.00	-25.00	510814.1247	678951.4446

NOTES:

- IF FURTHER INFORMATION REGARDING PROJECT CONTROL IS NEEDED, PLEASE CONTACT THE LOCATION AND SURVEYS UNIT.
- PROJECT CONTROL WAS ESTABLISHED USING GNSS, THE GLOBAL NAVIGATION SATELLITE SYSTEM.

Location and Surveys

PROJECT SURVEYOR

DOCUMENT NOT CONSIDERED FINAL UNLESS ALL SIGNATURES COMPLETED

I, Brian Barwatt, a Professional Land Surveyor in the state of North Carolina hereby certify to the best of my knowledge and belief that the following work item(s) (Base map Compilation, R/W Staking) performed under my responsible charge meet NCDOT Survey Standards as directed in the NCDOT Location & Surveys guidelines and procedures.

I further certify that the data compiled came from available surveys/mapping performed by others and provided to me by NCDOT and do not certify to the accuracy or quality of the individual data sources.

I further certify that the right of way and permanent easement points shown herein and outlined in the tables shown hereon (localized coordinates, station/offset) have been checked and are accurate representations of the right of way and permanent easement points depicted on the corresponding highway plans. I also certify that the right of way and permanent easement points shown herein have been field monumented under my supervision from existing survey control provided by others; that the depicted property data shown herein were surveyed by others; and these monuments denote the right of way and easement boundaries at the time of staking which may be subject to change due to right of way revisions (See deeds for final determination).

Witness my original signature, registration number and seal this 2nd day of January, 2024.

Designed by

 Professional Land Surveyor L-4727
 Seal

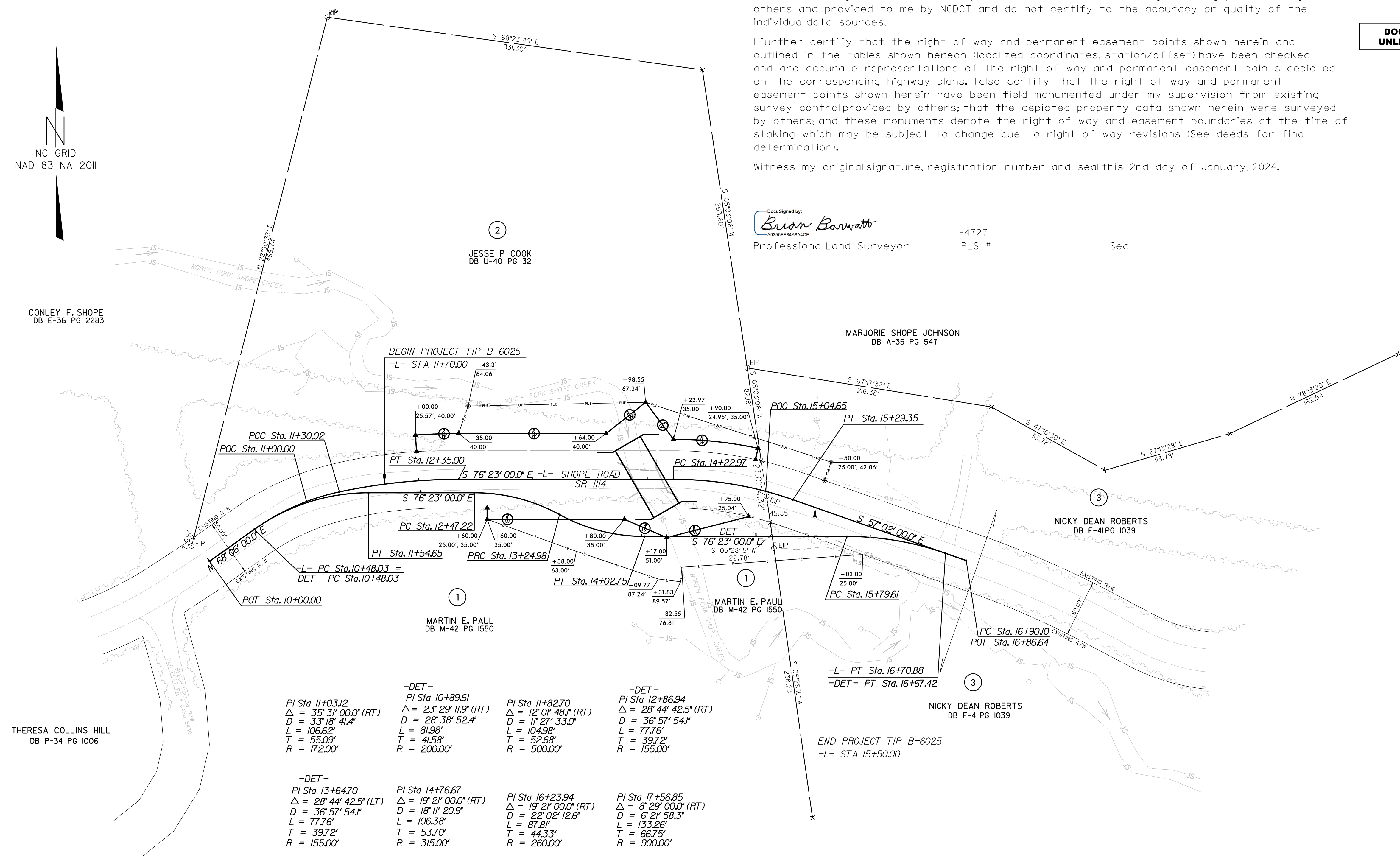

-DET- PI Sta 11+03.12 Δ = 35° 31' 00.0" (RT) D = 33' 18" 41.4" L = 106.62' T = 55.03' R = 172.00'	-DET- PI Sta 10+89.61 Δ = 23° 29' 11.9" (RT) D = 28' 38" 52.4" L = 81.98' T = 41.58' R = 200.00'	PI Sta 11+82.70 Δ = 12° 01' 48.1" (RT) D = 11' 27" 33.0" L = 104.98' T = 52.68' R = 500.00'	-DET- PI Sta 12+86.94 Δ = 28° 44' 42.5" (RT) D = 36' 57" 54.1" L = 77.76' T = 39.72' R = 155.00'
-DET- PI Sta 13+64.70 Δ = 28° 44' 42.5" (LT) D = 36' 57" 54.1" L = 77.76' T = 39.72' R = 155.00'	PI Sta 14+76.67 Δ = 19° 21' 00.0" (RT) D = 18' 11" 20.9" L = 106.38' T = 53.70' R = 315.00'	PI Sta 16+23.94 Δ = 19° 21' 00.0" (RT) D = 22° 02' 12.6" L = 87.81' T = 44.33' R = 260.00'	PI Sta 17+56.85 Δ = 8° 29' 00.0" (RT) D = 6' 21" 58.3" L = 133.28' T = 66.75' R = 900.00'

NOTES:

- IF FURTHER INFORMATION REGARDING PROJECT CONTROL IS NEEDED, PLEASE CONTACT THE LOCATION AND SURVEYS UNIT.
- PROJECT CONTROL WAS ESTABLISHED USING GNSS, THE GLOBAL NAVIGATION SATELLITE SYSTEM.

6/22/99
 K:\2024\Roadway\Proj\Survey\Control\550244_1s_rw04.dgn

STATE OF NORTH CAROLINA
DIVISION OF HIGHWAYS

TRANSPORTATION MANAGEMENT PLAN

MACON COUNTY

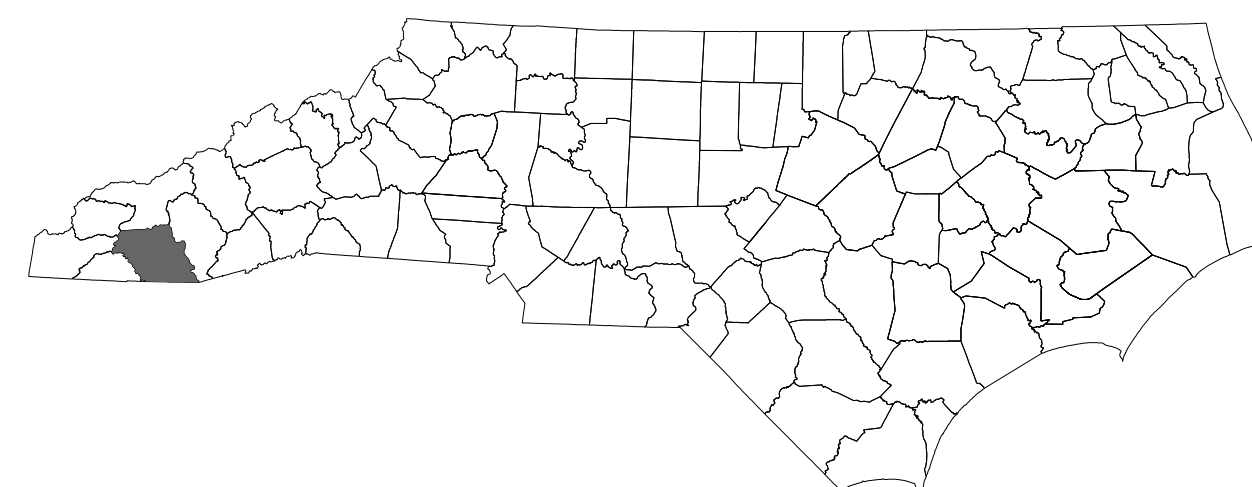

**LOCATION: BRIDGE #244 OVER NORTH FORK
COWEETA CREEK ON SR 1114 (SHOPE RD)**
TYPE OF WORK: GRADING, DRAINAGE, PAVING & STRUCTURES

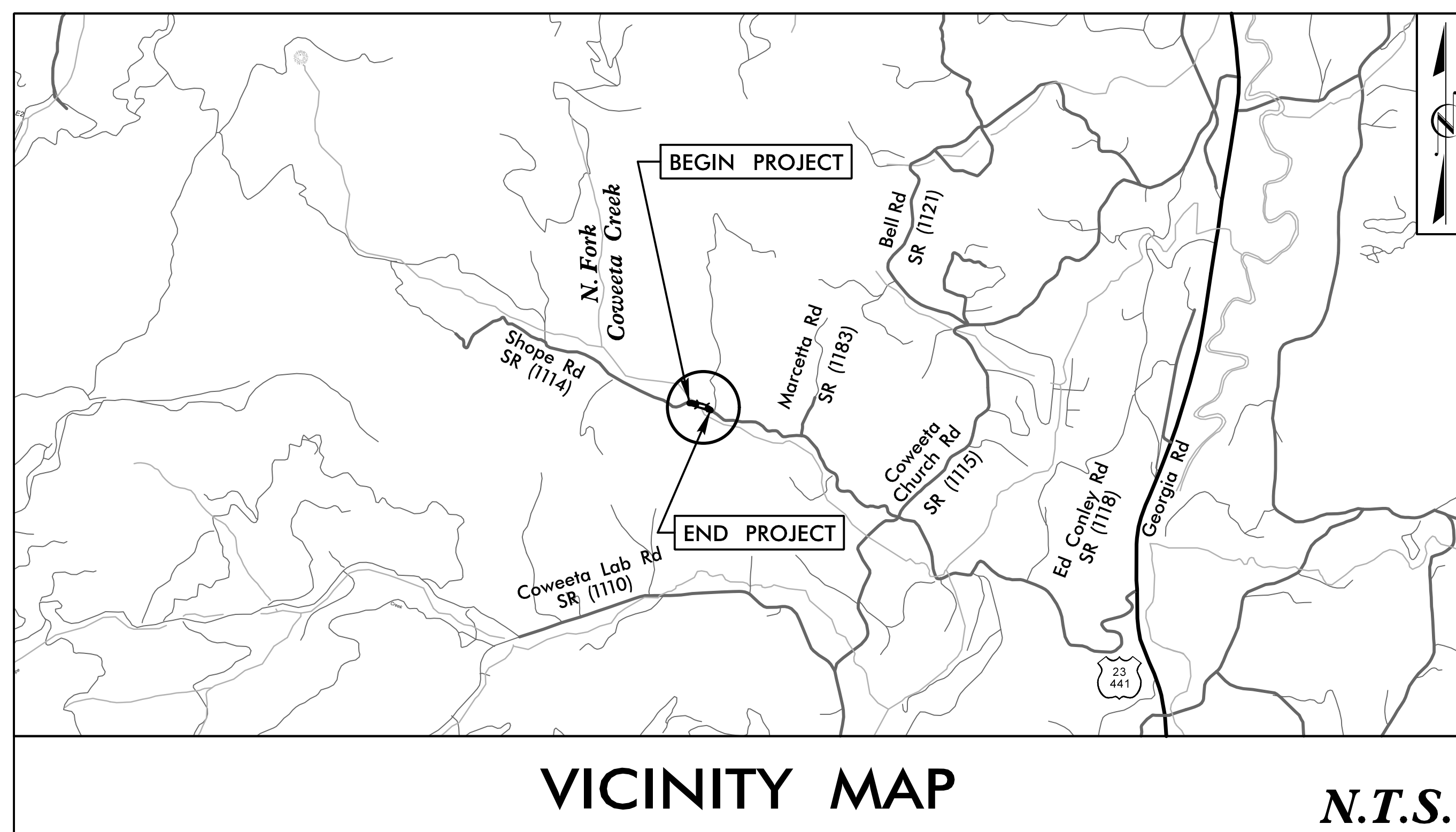

VICINITY MAP

N.T.S.

INDEX OF SHEETS	
SHEET NO.	TITLE
TMP-1	TITLE SHEET, VICINITY MAP, AND INDEX OF SHEETS
TMP-1A	LIST OF APPLICABLE ROADWAY STANDARD DRAWINGS, AND LEGEND
TMP-2	TRANSPORTATION OPERATIONS PLAN
TMP-2A	TEMPORARY SHORING NOTES
TMP-3	TEMPORARY TRAFFIC CONTROL PHASING
TMP-4	TEMPORARY TRAFFIC CONTROL PHASE I DETAIL
TMP-5	TEMPORARY TRAFFIC CONTROL PHASE II DETAIL

SHEET NO.
TMP-1

r:\Traffic\TrafficControl\TCPTCP_Sheets\VB\BP\4R\16\1_TCP_SHT_1.dgn
12/29/2023

PROJECT TIP: B-6025

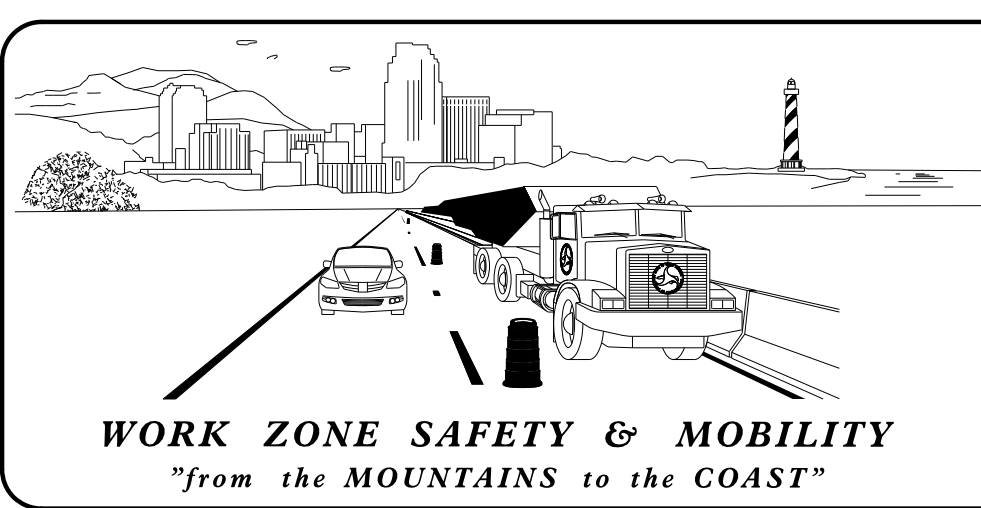

N.C.D.O.T. WORK ZONE TRAFFIC CONTROL
1561 MAIL SERVICE CENTER (MSG) RALEIGH, NC 27699-1561
750 N. GREENFIELD PARKWAY, GARNER, NC 27529 (DELIVERY)
PHONE: (919) 773-2800 FAX: (919) 771-2745

JOSEPH E. HUMMER, PE **STATE TRAFFIC MANAGEMENT ENGINEER**

_____ **TRAFFIC CONTROL PROJECT ENGINEER**

_____ **TRAFFIC CONTROL PROJECT DESIGN ENGINEER**

_____ **TRAFFIC CONTROL DESIGN ENGINEER**

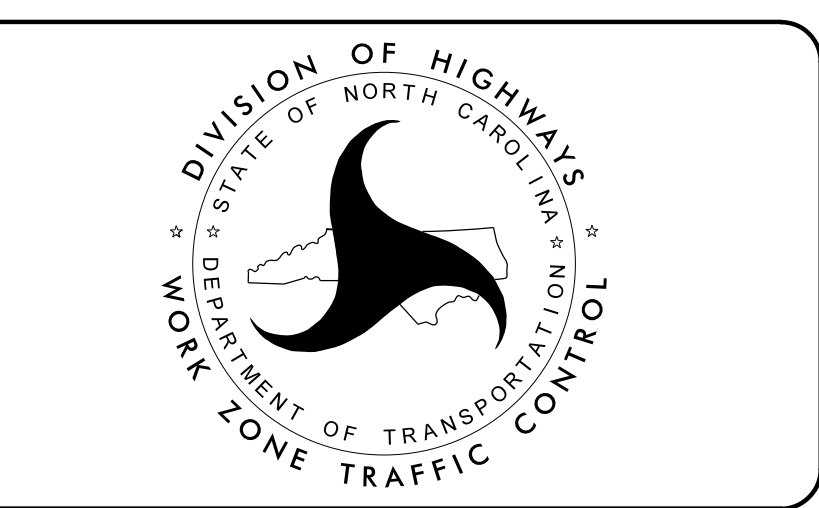

**DOCUMENT NOT CONSIDERED FINAL
UNLESS ALL SIGNATURES COMPLETED**

stv STV Engineers, Inc.
900 West Trade St., Suite 715
Charlotte, NC 28202
NC License Number F-0991

NIKKI T. HONEYCUTT, PE
TRAFFIC ENGINEER

CLARK GROVES
TRANSPORTATION DESIGNER

APPROVED: _____
DATE: 1/2/2024

PROJ. REFERENCE NO.	SHEET NO.
B-6025	TMP-1A



ROADWAY STANDARD DRAWINGS

THE FOLLOWING ROADWAY STANDARDS AS SHOWN IN "ROADWAY STANDARD DRAWINGS" - PROJECT SERVICES UNIT - N.C. DEPARTMENT OF TRANSPORTATION - RALEIGH, N.C., DATED JANUARY 2024 ARE APPLICABLE TO THIS PROJECT AND BY REFERENCE HEREBY ARE CONSIDERED A PART OF THESE PLANS:

STD. NO.	TITLE
1101.01	WORK ZONE WARNING SIGNS
1101.02	TEMPORARY LANE CLOSURES
1101.05	WORK ZONE VEHICLE ACCESSES
1101.11	TRAFFIC CONTROL DESIGN TABLES
1110.01	STATIONARY WORK ZONE SIGNS
1110.02	PORTABLE WORK ZONE SIGNS
1130.01	DRUM
1145.01	BARRICADES
1150.01	FLAGGING DEVICES
1205.01	PAVEMENT MARKINGS - LINE TYPES AND OFFSETS
1205.02	PAVEMENT MARKINGS - TWO-LANE AND MULTI-LANE ROADWAYS
1261.01	GUARDRAIL & BARRIER DELINEATOR SPACING
1261.02	GUARDRAIL & BARRIER DELINEATOR TYPES
1262.01	GUARDRAIL END DELINEATION

LEGEND

GENERAL

- DIRECTION OF TRAFFIC FLOW
- DIRECTION OF PEDESTRIAN TRAFFIC FLOW
- EXIST. PVMT.
- NORTH ARROW
- _____ PROPOSED PVMT.



TRAFFIC CONTROL DEVICES

- BARRICADE (TYPE III)
- CONE
- DRUM SKINNY DRUM TUBULAR MARKER
- TEMPORARY CRASH CUSHION
- FLASHING ARROW PANEL (TYPE C)
- FLAGGER
- LAW ENFORCEMENT
- TRUCK MOUNTED IMPACT ATTENUATOR (TMIA)
- CHANGEABLE MESSAGE SIGN

TEMPORARY SIGNING

- PORTABLE SIGN
- STATIONARY SIGN
- STATIONARY OR PORTABLE SIGN

SIGNALS

- PORTABLE TRAFFIC SIGNAL

TEMPORARY PAVEMENT MARKING

- PA WHITE EDGE LINE 4" PAINT
- P2 WHITE STOP BAR 24" PAINT

PAVEMENT MARKINGS

- _____ EXISTING LINES
- _____ TEMPORARY LINES

PAVEMENT MARKING SYMBOLS

- PAVEMENT MARKING SYMBOLS

12/29/2023 F:\TrafficControl\TCP_Sheets\7BP\4.R\61.TCP_SHT_1A.dgn owensc

APPROVED: _____ DATE: 1/2/2024			<p>LIST OF APPLICABLE ROADWAY STANDARD DRAWINGS & LEGEND</p>
SEAL	<p>DOCUMENT NOT CONSIDERED FINAL UNLESS ALL SIGNATURES COMPLETED</p>		

PROJECT NOTES

GENERAL NOTES

CHANGES MAY BE REQUIRED WHEN PHYSICAL DIMENSIONS IN THE DETAIL DRAWINGS, STANDARD DETAILS, AND ROADWAY DETAILS ARE NOT ATTAINABLE TO MEET FIELD CONDITIONS OR RESULT IN DUPLICATE OR UNDESIRED OVERLAPPING OF DEVICES. MODIFICATION MAY INCLUDE: MOVING, SUPPLEMENTING, COVERING, OR REMOVAL OF DEVICES AS DIRECTED BY THE ENGINEER.

THE FOLLOWING GENERAL NOTES APPLY AT ALL TIMES FOR THE DURATION OF THE CONSTRUCTION PROJECT EXCEPT WHEN OTHERWISE NOTED IN THE PLAN OR DIRECTED BY THE ENGINEER.

LANE AND SHOULDER CLOSURE REQUIREMENTS

- A) REMOVE LANE CLOSURE DEVICES FROM THE LANE WHEN WORK IS NOT BEING PERFORMED BEHIND THE LANE CLOSURE OR WHEN A LANE CLOSURE IS NO LONGER NEEDED OR AS DIRECTED BY THE ENGINEER.
- B) WHEN PERSONNEL AND/OR EQUIPMENT ARE WORKING WITHIN 15 FT OF AN OPEN TRAVEL LANE, CLOSE THE NEAREST OPEN SHOULDER USING ROADWAY STANDARD DRAWING NO. 1101.04 UNLESS THE WORK AREA IS PROTECTED BY BARRIER OR GUARDRAIL OR A LANE CLOSURE IS INSTALLED.
- C) WHEN PERSONNEL AND/OR EQUIPMENT ARE WORKING ON THE SHOULDER ADJACENT TO AN UNDIVIDED FACILITY AND WITHIN 5 FT OF AN OPEN TRAVEL LANE, CLOSE THE NEAREST OPEN TRAVEL LANE USING ROADWAY STANDARD DRAWING NO. 1101.02 UNLESS THE WORK AREA IS PROTECTED BY BARRIER OR GUARDRAIL.

WHEN PERSONNEL AND/OR EQUIPMENT ARE WORKING ON THE SHOULDER ADJACENT TO A DIVIDED FACILITY AND WITHIN 10 FT OF AN OPEN TRAVEL LANE, CLOSE THE NEAREST OPEN TRAVEL LANE USING ROADWAY STANDARD DRAWING NO. 1101.02 UNLESS THE WORK AREA IS PROTECTED BY BARRIER OR GUARDRAIL.

- D) WHEN PERSONNEL AND/OR EQUIPMENT ARE WORKING WITHIN A LANE OF TRAVEL OF AN UNDIVIDED OR DIVIDED FACILITY, CLOSE THE LANE ACCORDING TO THE TRAFFIC CONTROL PLANS, ROADWAY STANDARD DRAWINGS, OR AS DIRECTED BY THE ENGINEER. CONDUCT THE WORK SO THAT ALL PERSONNEL AND/OR EQUIPMENT REMAIN WITHIN THE CLOSED TRAVEL LANE.
- E) DO NOT WORK SIMULTANEOUSLY WITHIN 15 FT ON BOTH SIDES OF AN OPEN TRAVELWAY, RAMP, OR LOOP WITHIN THE SAME LOCATION UNLESS PROTECTED WITH GUARDRAIL OR BARRIER.

PAVEMENT EDGE DROP OFF REQUIREMENTS

- F) BACKFILL AT A 6:1 SLOPE UP TO THE EDGE AND ELEVATION OF EXISTING PAVEMENT IN AREAS ADJACENT TO AN OPENED TRAVEL LANE THAT HAS AN EDGE OF PAVEMENT DROP-OFF AS FOLLOWS:

BACKFILL DROP-OFFS THAT EXCEED 2 INCHES ON ROADWAYS WITH POSTED SPEED LIMITS OF 45 MPH OR GREATER.

BACKFILL DROP-OFFS THAT EXCEED 3 INCHES ON ROADWAYS WITH POSTED SPEED LIMITS LESS THAN 45 MPH.

BACKFILL WITH SUITABLE COMPACTED MATERIAL, AS APPROVED BY THE ENGINEER, AT NO EXPENSE TO THE DEPARTMENT.

- G) DO NOT EXCEED A DIFFERENCE OF 2 INCHES IN ELEVATION BETWEEN OPEN LANES OF TRAFFIC FOR NOMINAL LIFTS OF 1.5 INCHES. INSTALL ADVANCE WARNING "UNEVEN LANES" SIGNS (W8-11) 350 ft IN ADVANCE AND A MINIMUM OF EVERY HALF MILE THROUGHOUT THE UNEVEN AREA.

TRAFFIC PATTERN ALTERATIONS

- H) NOTIFY THE ENGINEER TWENTY ONE (21) CALENDAR DAYS PRIOR TO ANY TRAFFIC PATTERN ALTERATION.

SIGNING

- I) INSTALL ADVANCE WORK ZONE WARNING SIGNS WHEN WORK IS WITHIN 40 FT FROM THE EDGE OF TRAVEL LANE AND NO MORE THAN THREE (3) DAYS PRIOR TO THE BEGINNING OF CONSTRUCTION.
- J) ENSURE ALL NECESSARY SIGNING IS IN PLACE PRIOR TO ALTERING ANY TRAFFIC PATTERN.

TRAFFIC CONTROL DEVICES

- K) WHEN LANE CLOSURES ARE NOT IN EFFECT SPACE CHANNELIZING DEVICES IN WORK AREAS NO GREATER IN FEET THAN TWICE THE POSTED SPEED LIMIT (MPH) EXCEPT, 10 FT ON-CENTER IN RADII, AND 3 FT OFF THE EDGE OF AN OPEN TRAVELWAY. REFER TO STANDARD SPECIFICATIONS FOR ROADS AND STRUCTURES SECTIONS 1130 (DRUMS), 1135 (CONES) AND 1180 (SKINNY DRUMS) FOR ADDITIONAL REQUIREMENTS.
- L) PLACE ADDITIONAL SETS OF THREE CHANNELIZING DEVICES PERPENDICULAR TO THE EDGE OF TRAVELWAY ON 500 FT CENTERS WHEN OPENED LANES ARE CLOSED TO TRAFFIC.

PAVEMENT MARKINGS AND MARKERS

- M) INSTALL TEMPORARY PAVEMENT MARKINGS AND TEMPORARY PAVEMENT MARKERS ON INTERIM LAYERS OF PAVEMENT AS FOLLOWS:

<u>ROAD NAME</u>	<u>MARKING</u>	<u>MARKER</u>
SR 1114 (SHOPE RD) (-L-)	PAINT	NONE
DETOUR (-DET-)	PAINT	NONE

- N) PLACE ONE APPLICATION OF PAINT FOR TEMPORARY TRAFFIC PATTERNS. PLACE A SECOND APPLICATION OF PAINT SIX (6) MONTHS AFTER THE INITIAL APPLICATION AND EVERY SIX MONTHS AS DIRECTED BY THE ENGINEER.
- O) TIE PROPOSED PAVEMENT MARKING LINES TO EXISTING PAVEMENT MARKING LINES.
- P) REMOVE/REPLACE ANY CONFLICTING/DAMAGED PAVEMENT MARKINGS AND MARKERS BY THE END OF EACH DAY'S OPERATION.

MISCELLANEOUS

- Q) IN THE EVENT A TIE-IN CANNOT BE MADE IN ONE DAY'S TIME, BRING THE TIE-IN AREA TO AN APPROPRIATE ROADWAY ELEVATION AS DETERMINED BY THE ENGINEER. PLACE BLACK ON ORANGE "LOOSE GRAVEL" SIGNS (W8-7) AND BLACK ON ORANGE "PAVEMENT ENDS" SIGNS (W8-3) 100 FT AND 200 FT RESPECTIVELY IN ADVANCE OF THE UNEVEN AREAS. USE DRUMS TO DELINEATE THE EDGE OF ROADWAY ALONG UNPAVED AREAS.

LOCAL NOTES

1. CONTACT MACON COUNTY EMERGENCY SERVICES AND SCHOOLS AT LEAST ONE MONTH PRIOR TO CONSTRUCTION.
2. THE CONTRACTOR SHALL BUILD AS MUCH AS POSSIBLE AWAY FROM TRAFFIC.

MANAGEMENT STRATEGIES

THE PROPOSED CULVERT WILL BE CONSTRUCTED USING A COMBINATION OF ONSITE DETOUR AND LANE CLOSURES UTILIZING FLAGGERS AS NEEDED.

PHASE I - TRAFFIC WILL BE MAINTAINED ON THE EXISTING ROAD, BUT REDUCED TO ONE LANE USING FLAGGERS AS THE DETOUR ALIGNMENT IS CONSTRUCTED.

PHASE II - TRAFFIC WILL BE SHIFTED TO ONE LANE ON THE DETOUR ALIGNMENT USING TEMPORARY SIGNALS AND PAVEMENT MARKINGS WHILE THE PROPOSED CULVERT IS CONSTRUCTED. A FLAGGING OPERATION WILL BE USED TO CONSTRUCT THE NEW TIE-INS.

PHASE III - THE TEMPORARY TRAFFIC SIGNALS WILL BE REMOVED AND TWO WAY TRAFFIC WILL BE MAINTAINED USING TEMPORARY LANE CLOSURES TO CONSTRUCT THE FINAL PAVEMENT SURFACE AND PAVEMENT MARKINGS.

12/29/2023
F:\Traffic\TrafficControl\TCP\TCP Sheets\7BP\4.R\6\1\TCP_SHT_2.dgn
dwenisc

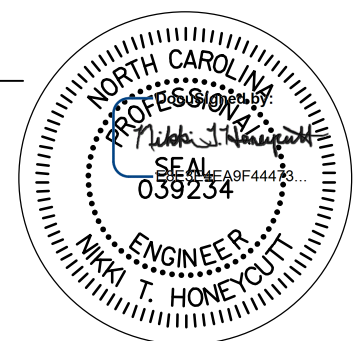
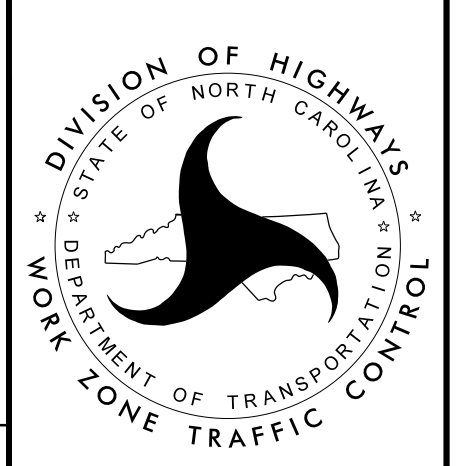
APPROVED: _____ DATE: 1/2/2024 <div style="text-align: center; margin-top: 20px;">  </div>		<h2 style="margin: 0;">TRANSPORTATION OPERATIONS PLAN</h2>
DOCUMENT NOT CONSIDERED FINAL UNLESS ALL SIGNATURES COMPLETED		

PROJ. REFERENCE NO.	SHEET NO.
B-6025	TMP-3



PROJECT PHASING

PHASE I

- STEP 1: INSTALL ADVANCED WORK ZONE WARNING SIGNS IN ACCORDANCE TO NCDOT RSD. 1101.01 SHEET 3 OF 3.
- STEP 2: CONSTRUCT TEMPORARY DETOUR ROUTE FROM -DET- STATION 12+90± TO STATION 15+75±. MAINTAIN ACCESS TO DRIVEWAY. SEE ROADWAY AND STRUCTURE PLANS.
- STEP 3: USING NCDOT RSD. 1101.02 SHEET 17 OF 19, INSTALL PORTABLE TRAFFIC SIGNALS. INSTALL TEMPORARY DETOUR ROUTE FROM -DET- STATION 11+46± TO STATION 12+90± AND STATION 15+75± TO STATION 16+22±. INSTALL SIGNING, TEMPORARY PAVEMENT MARKINGS, TEMPORARY GUARDRAIL, TEMPORARY SHORING, AND DRUMS AS SHOWN ON SHEET TMP-4.

PHASE II

- STEP 1: ONCE SIGNS AND DEVICES ARE IN PLACE, ACTIVATE PORTABLE TRAFFIC SIGNALS AND PLACE TRAFFIC INTO A ONE-LANE, TWO-WAY OPERATION.
- STEP 2: AWAY FROM TRAFFIC, PERFORM THE FOLLOWING:
 - REMOVE EXISTING STRUCTURE 550244 AND CONSTRUCT PROPOSED STRUCTURE FROM -L- STATION 13+86.42 TO STATION 14+15.58. SEE ROADWAY AND STRUCTURE PLANS.
 - CONSTRUCT PROPOSED -L- INCLUDING ONE LAYER OF FINAL SURFACE COURSE FROM -L- STATION 11+70± TO STATION 15+50±.
- STEP 3: USING NCDOT RSD. 1101.02, PLACE FINAL LAYER OF SURFACE COURSE AND FINAL PAVEMENT MARKINGS FROM -L- STATION 11+70± TO STATION 15+50±

PHASE III

- STEP 1: SWITCH TRAFFIC TO -L- TO A TWO LANE, TWO-WAY OPERATION. REMOVE TEMPORARY DETOUR FROM -DET- STATION 11+46± TO STATION 16+23±.
- STEP 2: REMOVE ALL TRAFFIC CONTROL DEVICES, SIGNING, AND DETOUR ROUTE SIGNING.
 - OPEN SR 1114 TO FINAL TRAFFIC PATTERN.

12/29/2023
 F:\TrafficControl\TCP\TCP Sheets\78P_14.R\61_TCP_SHT_3.dgn
 dweinsc

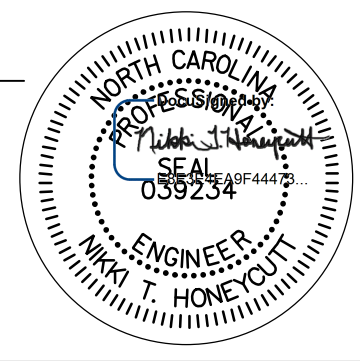
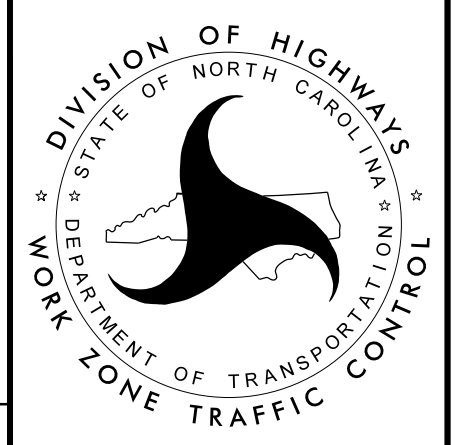
APPROVED: _____ DATE: 1/2/2024 <div style="text-align: center; margin-top: 20px;">  SEAL </div>		<h3 style="margin: 0;">TEMPORARY TRAFFIC CONTROL PHASING</h3>
DOCUMENT NOT CONSIDERED FINAL UNLESS ALL SIGNATURES COMPLETED		

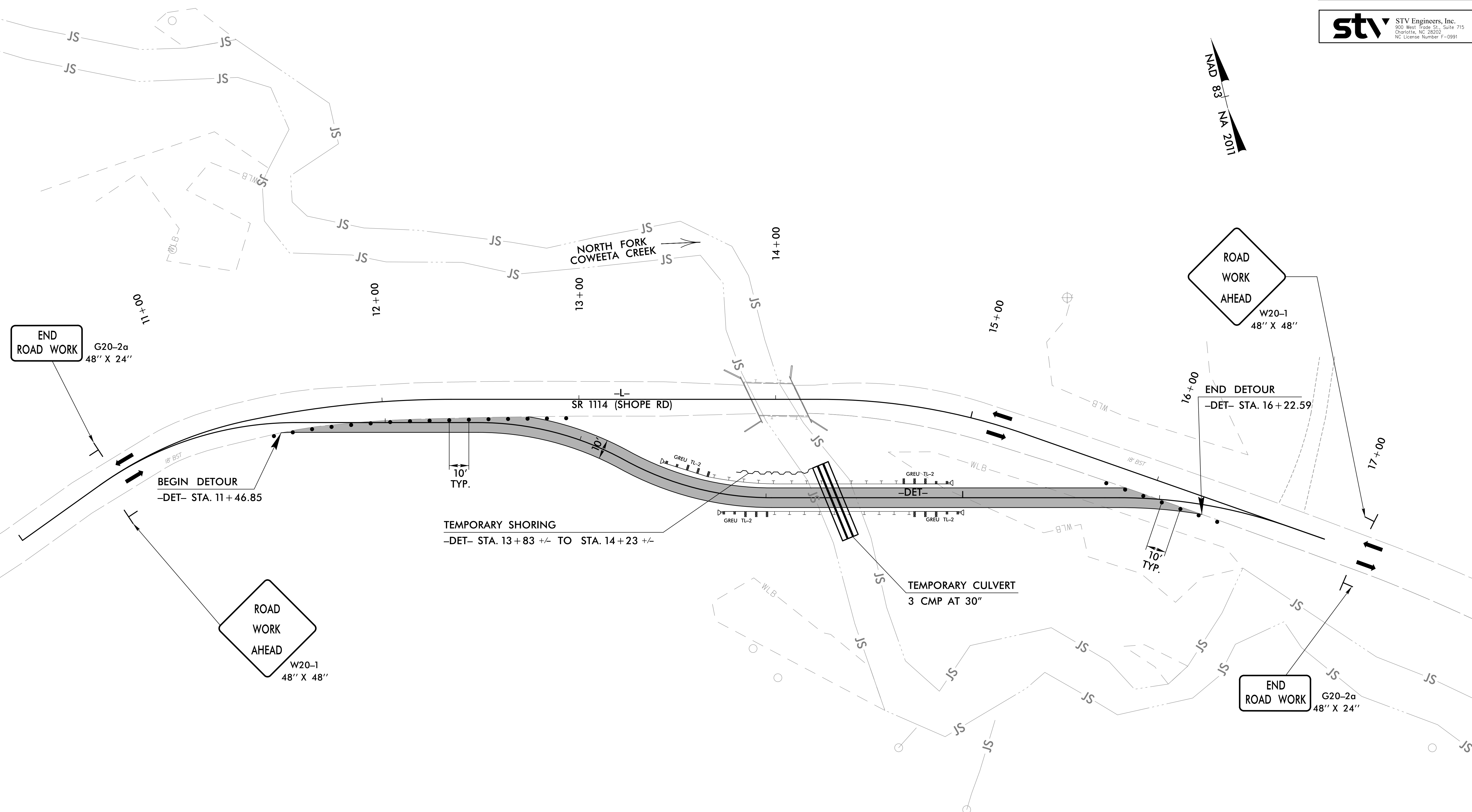
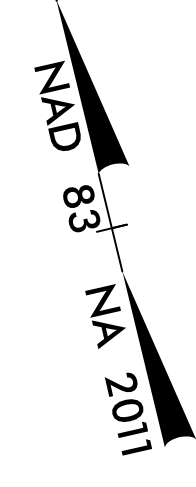

END ROAD WORK
G20-2a
48" X 24"

BEGIN DETOUR
-DET- STA. 11+46.85

TEMPORARY SHORING
-DET- STA. 13+83 +/- TO STA. 14+23 +/-

TEMPORARY CULVERT
3 CMP AT 30"

END DETOUR
-DET- STA. 16+22.59

END ROAD WORK
G20-2a
48" X 24"

SEE SHEET 2B-1 FOR -DET- PLAN & PROFILE

12/29/2023
F:\TrafficControl\TCP\TCP Sheets\7BP_14.R\161.TCP_SHT_4.dgn
dwehnc

SCALE 1" = 25'

APPROVED: _____
DATE: 1/2/2024

SEAL

DOCUMENT NOT CONSIDERED FINAL
UNLESS ALL SIGNATURES COMPLETED

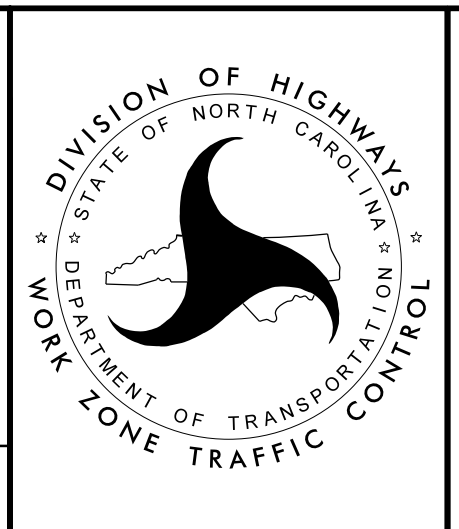

TEMPORARY TRAFFIC CONTROL
PHASE I DETAIL

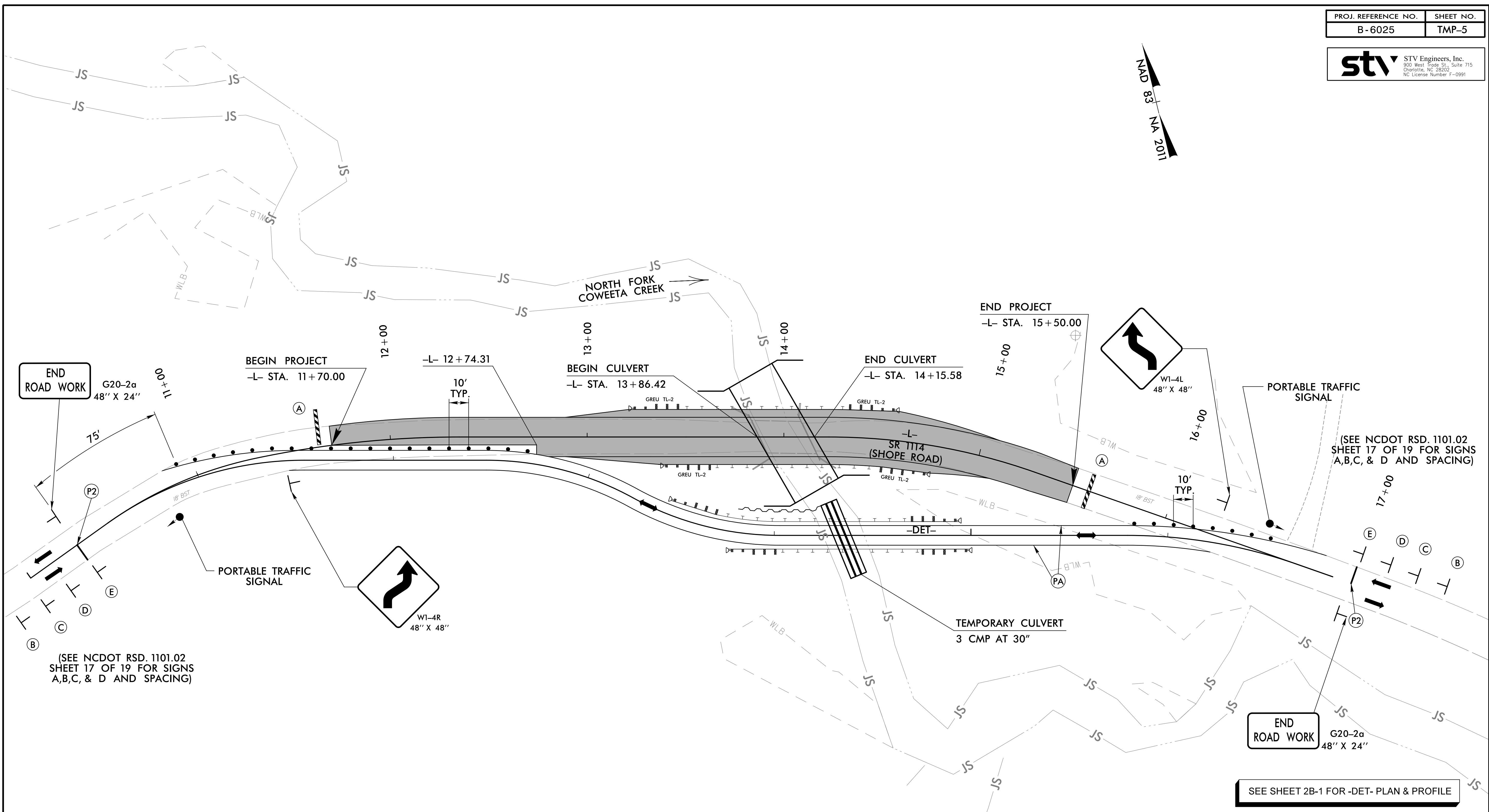
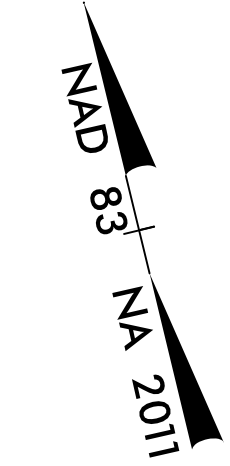

(SEE NCDOT RSD. 1101.02 SHEET 17 OF 19 FOR SIGNS A,B,C, & D AND SPACING)

(SEE NCDOT RSD. 1101.02 SHEET 17 OF 19 FOR SIGNS A,B,C, & D AND SPACING)

SEE SHEET 2B-1 FOR -DET- PLAN & PROFILE

SCALE 1" = 25'

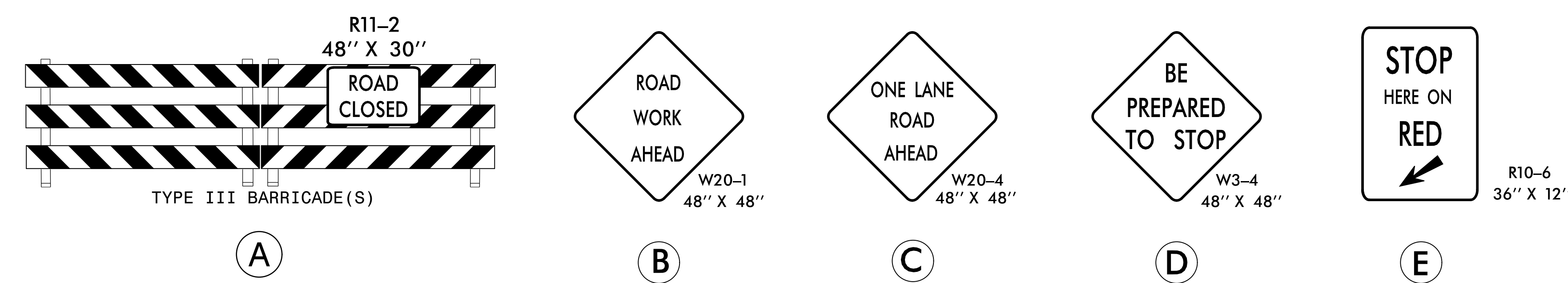

APPROVED: _____
 DATE: 1/2/2024
 SEAL

DOCUMENT NOT CONSIDERED FINAL
 UNLESS ALL SIGNATURES COMPLETED

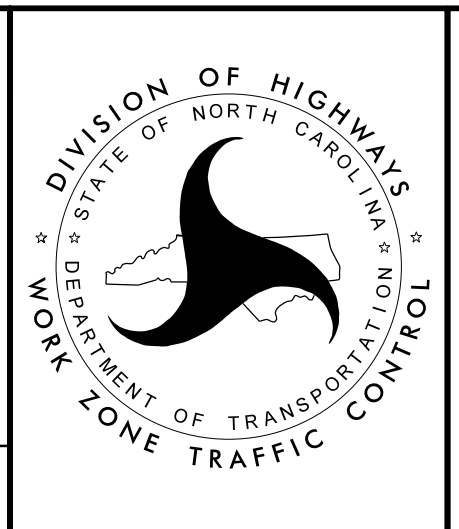

TEMPORARY TRAFFIC CONTROL
 PHASE II DETAIL

12/29/2023 F:\TrafficControl\TCP\TCP_Sheets\7BP_4.R\61.TCP_SHT_5.dgn dwwensc

PROJ. REFERENCE NO.	SHEET NO.
B-6025	PMP-1

stv STV Engineers, Inc.
 900 West Trade St., Suite 715
 Charlotte, NC 28202
 NC License Number F-0991

BRIDGE #550224

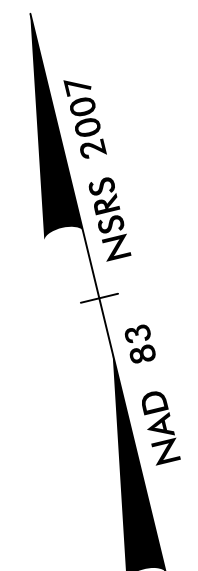

PAVEMENT MARKING PLAN

ROADWAY STANDARD DRAWING

THE FOLLOWING ROADWAY STANDARDS AS SHOWN IN "ROADWAY STANDARD DRAWINGS" - PROJECT SERVICES UNIT - N.C. DEPARTMENT OF TRANSPORTATION - RALEIGH, N.C., DATED JANUARY 2024 ARE APPLICABLE TO THIS PROJECT AND BY REFERENCE HEREBY ARE CONSIDERED A PART OF THESE PLANS:

STD. NO.	TITLE
1205.01	PAVEMENT MARKINGS - LINE TYPES AND OFFSETS
1205.02	PAVEMENT MARKINGS - TWO LANE AND MULTILANE ROADWAYS
1261.01	GUARDRAIL & BARRIER DELINEATORS - INSTALLATION SPACING
1261.02	GUARDRAIL & BARRIER DELINEATORS - TYPES AND MOUNTING
1262.01	GUARDRAIL END DELINEATION

GENERAL NOTES

THE FOLLOWING GENERAL NOTES APPLY AT ALL TIMES FOR THE DURATION OF THE CONSTRUCTION PROJECT, EXCEPT WHEN OTHERWISE NOTED IN THE PLAN, OR DIRECTED BY THE ENGINEER.

- A. INSTALL PAVEMENT MARKINGS ON THE FINAL SURFACE.
- ROAD NAME: SR 1114 (SHOPE ROAD RD) MARKING: PAINT
- B. TIE PROPOSED PAVEMENT MARKING LINES TO EXISTING PAVEMENT MARKING LINES.
- C. REMOVE/REPLACE ANY CONFLICTING/DAMAGED PAVEMENT MARKINGS AND MARKERS.
- C. TEMPORARY PAVEMENT MARKINGS ARE PLACED IN ONE(1) COAT OF PAINT, AND FINAL PAVEMENT MARKINGS ARE PLACED IN TWO(2) COATS OF PAINT.

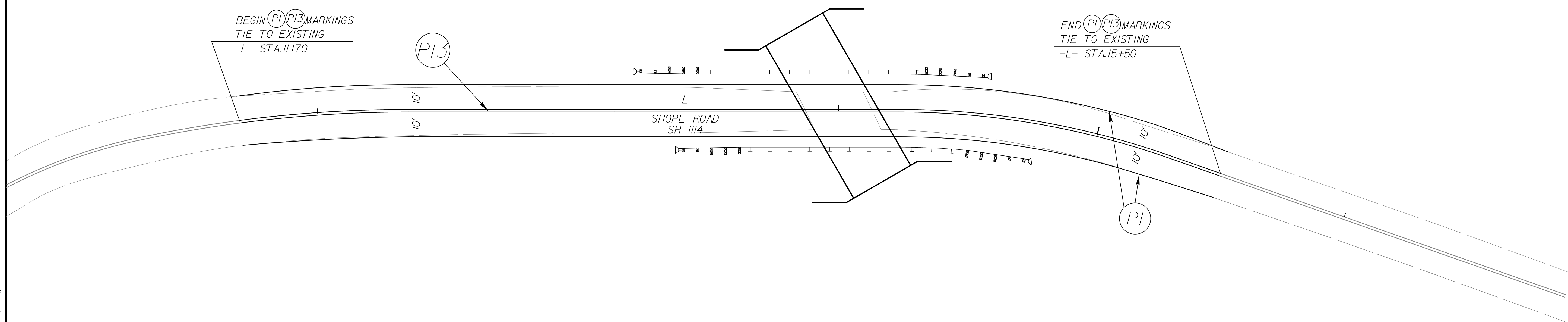

BEGIN (P1)(P13) MARKINGS
 TIE TO EXISTING
 -L- STA. 11+70

END (P1)(P13) MARKINGS
 TIE TO EXISTING
 -L- STA. 15+50

PAVEMENT MARKING SCHEDULE

MARKING	DESCRIPTION	LENGTH (LF)
P1 - PAINT (4" WHITE)	WHITE EDGELINE	760 LF
P13 - PAINT (4" YELLOW)	DOUBLE YELLOW CENTER LINE	380 LF

**DOCUMENT NOT CONSIDERED FINAL
 UNLESS ALL SIGNATURES COMPLETED**

APPROVED: _____ DATE: 1/27/2024

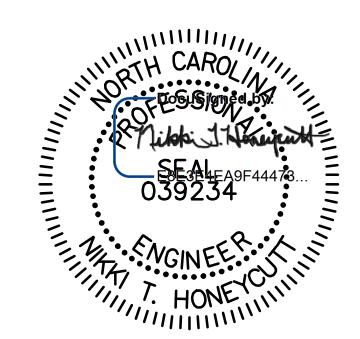

PAVEMENT MARKING DETAIL

SCALE: 20
 DATE: 2/1/18
 DWG. BY: ERW
 DESIGN BY: ERW
 REVIEWED BY: MBE

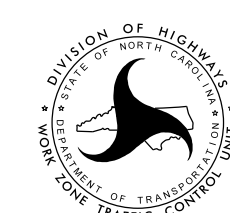

REVISIONS	

R:\T\traffic\TrafficControl\NMP\7\BP\4R\6\1_rdy_pmp01.dgn 12/29/2023

TIP PROJECT: B-6025

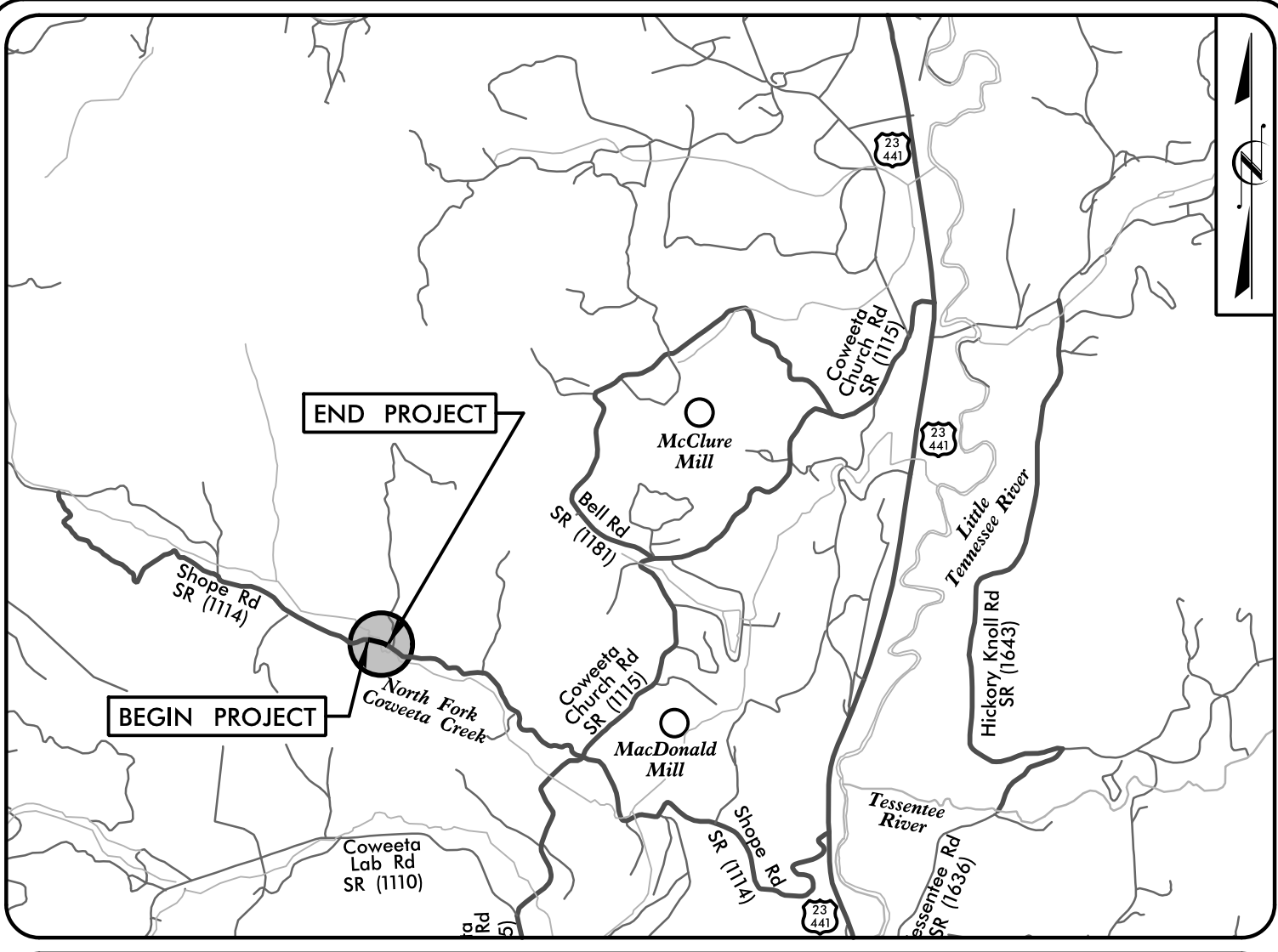

VICINITY MAP
NOT TO SCALE

STATE OF NORTH CAROLINA
DIVISION OF HIGHWAYS
**PLAN FOR PROPOSED
HIGHWAY EROSION CONTROL**
MACON COUNTY

**LOCATION: BRIDGE #550244 OVER N.FORK COWEETA CREEK
ON SR 1114 (SHOPE RD)**
TYPE OF WORK: GRADING, PAVING, DRAINAGE, & STRUCTURE

STATE	STATE PROJECT REFERENCE NO.	SHEET NO.	TOTAL SHEETS
N.C.	B-6025	EC-1	14
STATE PROJ. NO.	F.A. PROJ. NO.	DESCRIPTION	
48220.1.1	1114(009)	P.E.	
48220.2.1	1114(009)	ROW & UTILITIES	
48220.3.1	1114(009)	CONSTRUCTION	

BEGIN PROJECT TIP B-6025
-L- STA. 11 + 70.00

END PROJECT TIP B-6025
-L- STA. 15 + 50.00

THIS PROJECT HAS BEEN DESIGNED TO SENSITIVE WATERSHED STANDARDS.

ENVIRONMENTALLY SENSITIVE AREA(S) EXIST ON THIS PROJECT

Refer To E. C. Special Provisions for Special Considerations.

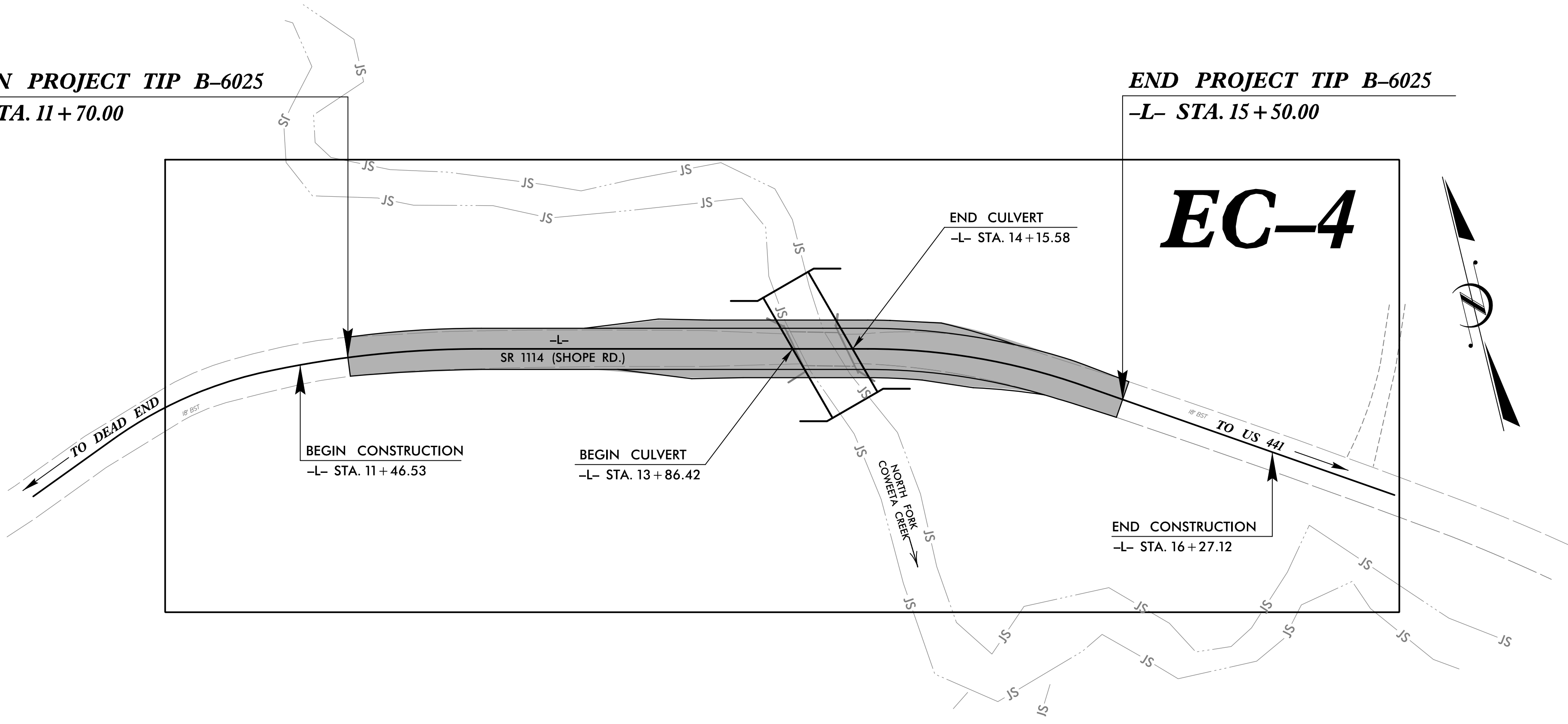

THIS PROJECT CONTAINS EROSION CONTROL PLANS FOR CLEARING AND GRUBBING PHASE OF CONSTRUCTION.

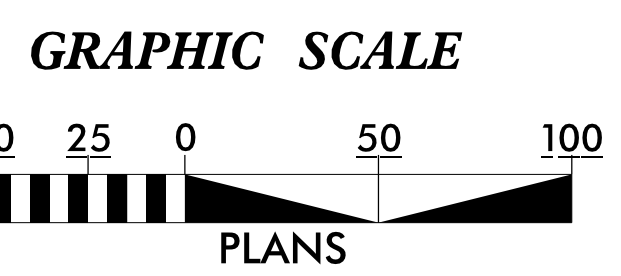

THESE EROSION AND SEDIMENT CONTROL PLANS COMPLY WITH THE APPLICABLE REGULATIONS SET FORTH BY THE NCG-010000 GENERAL CONSTRUCTION PERMIT EFFECTIVE APRIL 1, 2019 AND ISSUED BY THE NORTH CAROLINA DEPARTMENT OF ENVIRONMENTAL QUALITY DIVISION OF WATER RESOURCES.

stv
STV Engineers, Inc.
900 West Trade St., Suite 715
Charlotte, NC 28202
NC License Number F-0991

Prepared In the Office of:
STV Engineers, Inc.
900 West Trade St., Suite 715
Charlotte, NC 28202

Designed by:
HALEY SMITH, EIT 4688
NAME LEVEL III CERTIFICATION NO.

Roadway Standard Drawings

The "Roadway Standard Drawings"- Roadway Design Unit - N. C. Department of Transportation - Raleigh, N. C., dated January 2024 and the latest revision thereto are applicable to this project and by reference hereby are considered a part of these plans.

I:\projects\2024\11-11-24\11-11-24-EC-Sheets\17BP14R161-hyd-EC-1-plan.dgn

DIVISION OF HIGHWAYS STATE OF NORTH CAROLINA

EROSION & SEDIMENT CONTROL LEGEND

Std. #	Description	Symbol	Std. #	Description	Symbol
1605.01	Temporary Silt Fence		1633.01	Temporary Rock Silt Check Type A	
1606.01	Special Sediment Control Fence		1633.02	Temporary Rock Silt Check Type B	
1622.01	Temporary Berms and Slope Drains		1633.03	Temporary Rock Silt Check Type A with Excelsior Matting and Flocculant	
1630.02	Silt Basin Type B		1634.01	Temporary Rock Sediment Dam Type A	
1630.03	Temporary Silt Ditch		1634.02	Temporary Rock Sediment Dam Type B	
1630.04	Stilling Basin		1635.01	Rock Pipe Inlet Sediment Trap Type A	
1630.05	Temporary Diversion		1635.02	Rock Pipe Inlet Sediment Trap Type B	
1630.06	Special Stilling Basin		1636.01	Excelsior Wattle Check	
1630.07	Skimmer Basin		1636.01	Excelsior Wattle Check with Flocculant	
1630.08	Tiered Skimmer Basin		1636.01	Coir Fiber Wattle Check	
1630.09	Earthen Dam with Skimmer		1636.01	Coir Fiber Wattle Check with Flocculant	
	Infiltration Basin		1636.02	Silt Fence Excelsior Wattle Break	
	Rock Inlet Sediment Trap:			Silt Fence Coir Fiber Wattle Break	
1632.01	Type A	A	1636.03	Excelsior Wattle Barrier	
1632.02	Type B	B	1636.03	Coir Fiber Wattle Barrier	
1632.03	Type C	C			

ONSITE CONCRETE WASHOUT STRUCTURE WITH LINER

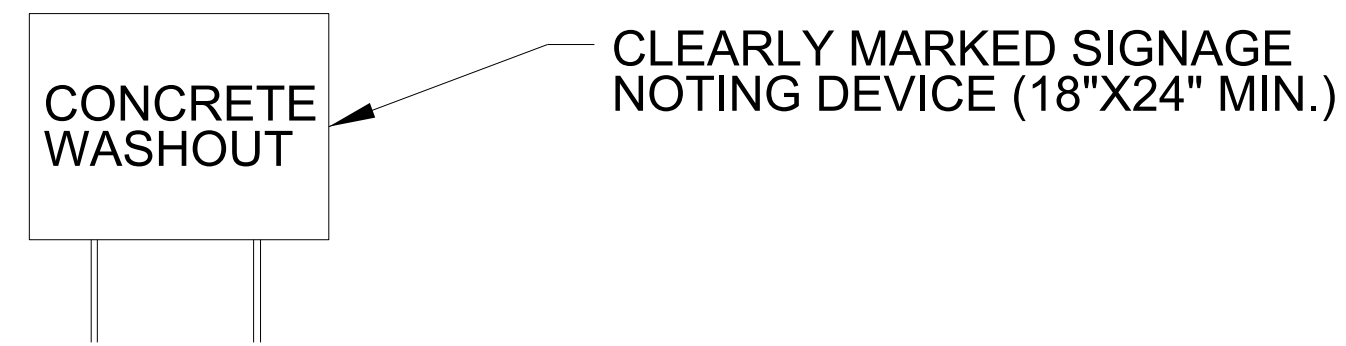
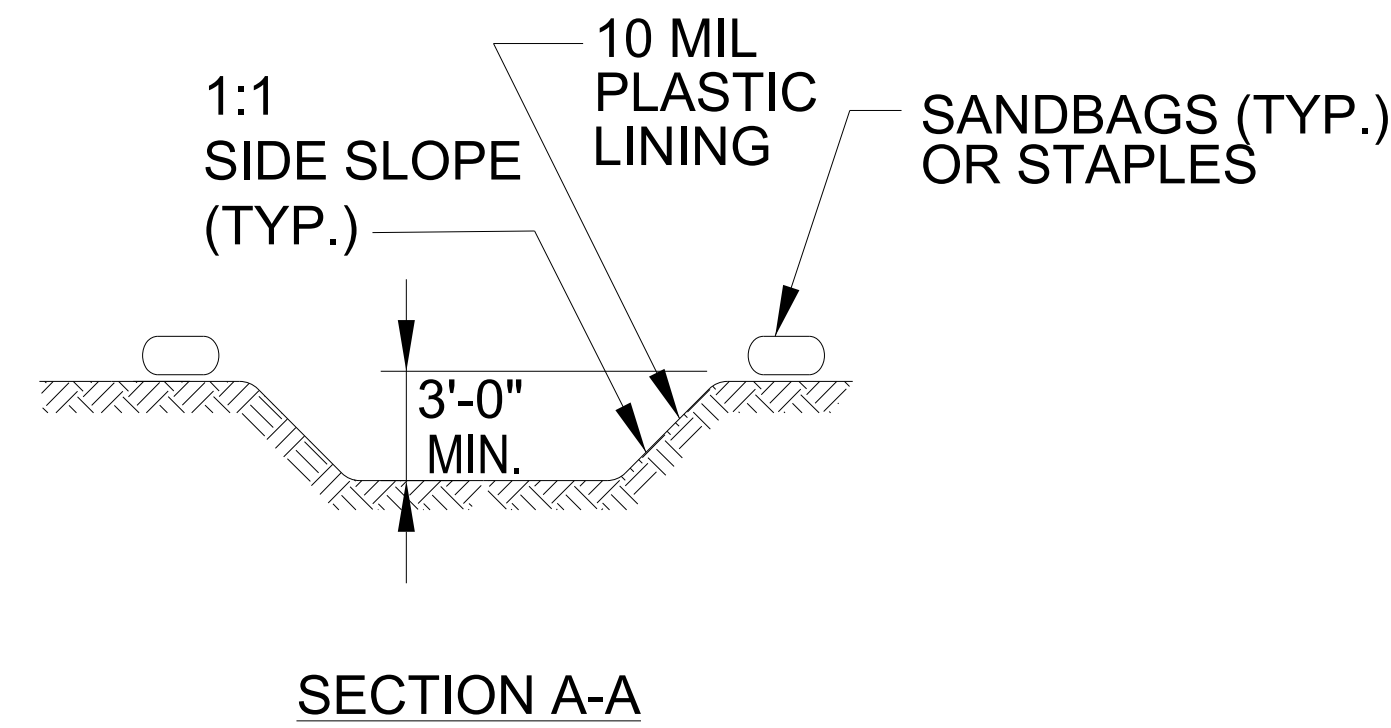
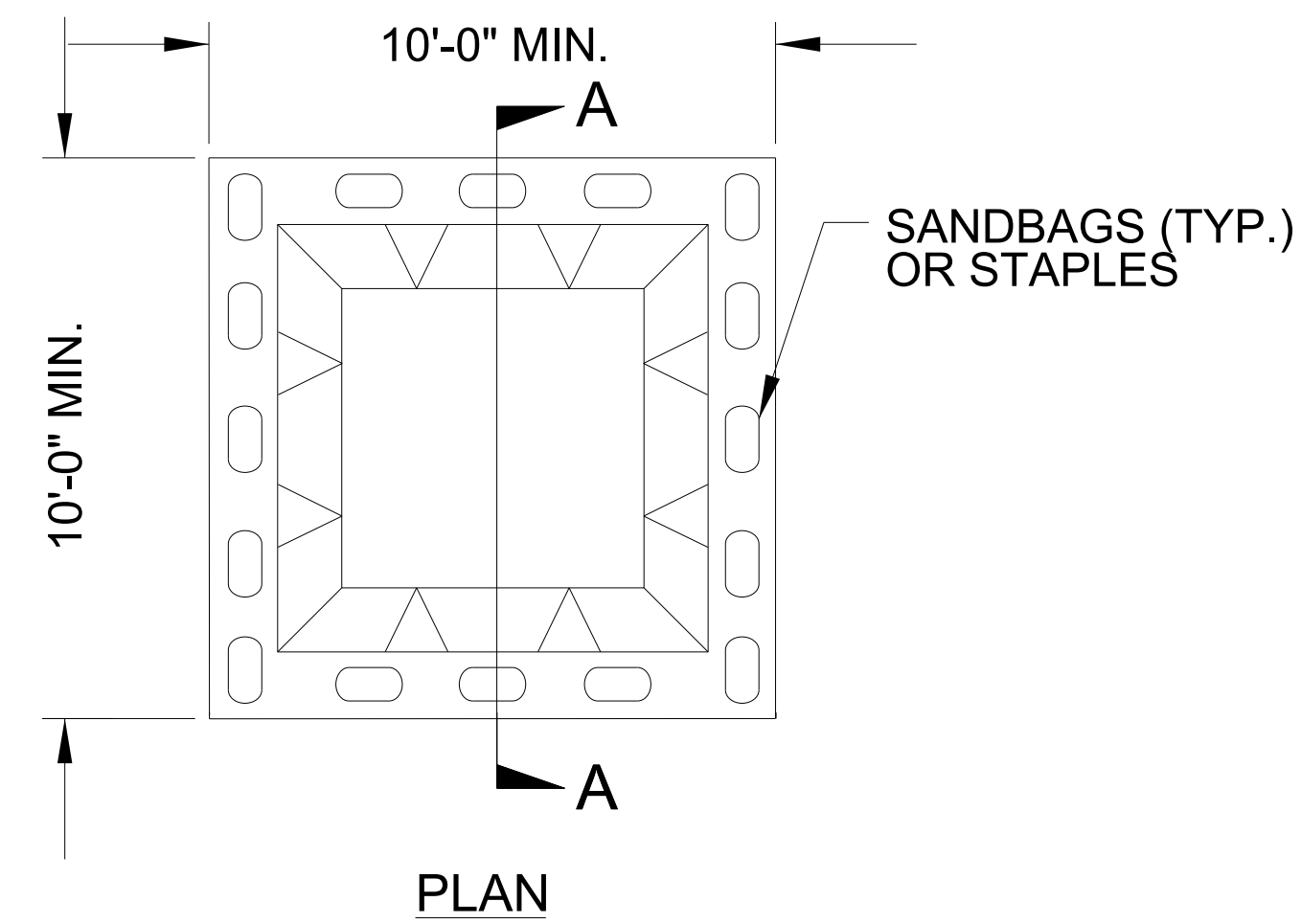

BELOW GRADE WASHOUT STRUCTURE
NOT TO SCALE

- NOTES:**
1. ACTUAL LOCATION DETERMINED IN FIELD
 2. THE CONCRETE WASHOUT STRUCTURES SHALL BE MAINTAINED WHEN THE LIQUID AND/OR SOLID REACHES 75% OF THE STRUCTURES CAPACITY TO PROVIDE ADEQUATE HOLDING CAPACITY WITH A MINIMUM 12 INCHES OF FREEBOARD.
 3. CONCRETE WASHOUT STRUCTURE NEEDS TO BE CLEARLY MARKED WITH SIGNAGE NOTING DEVICE.

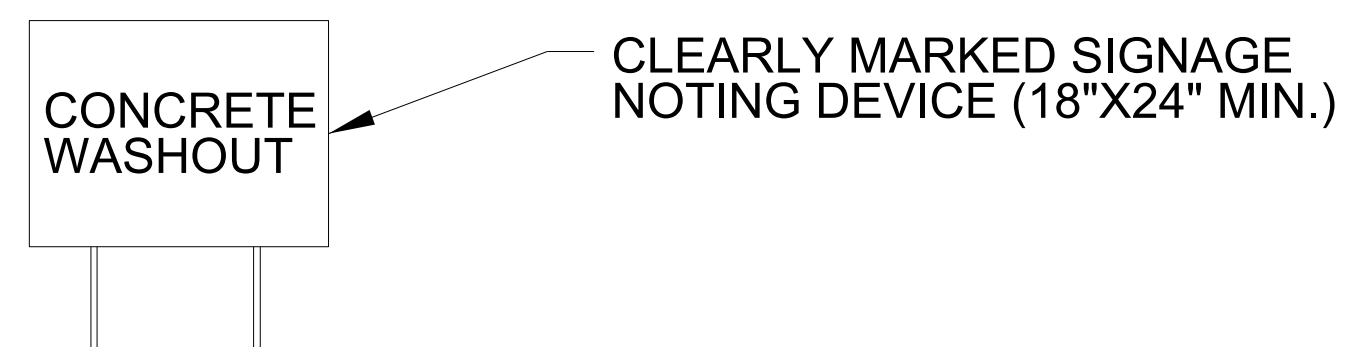
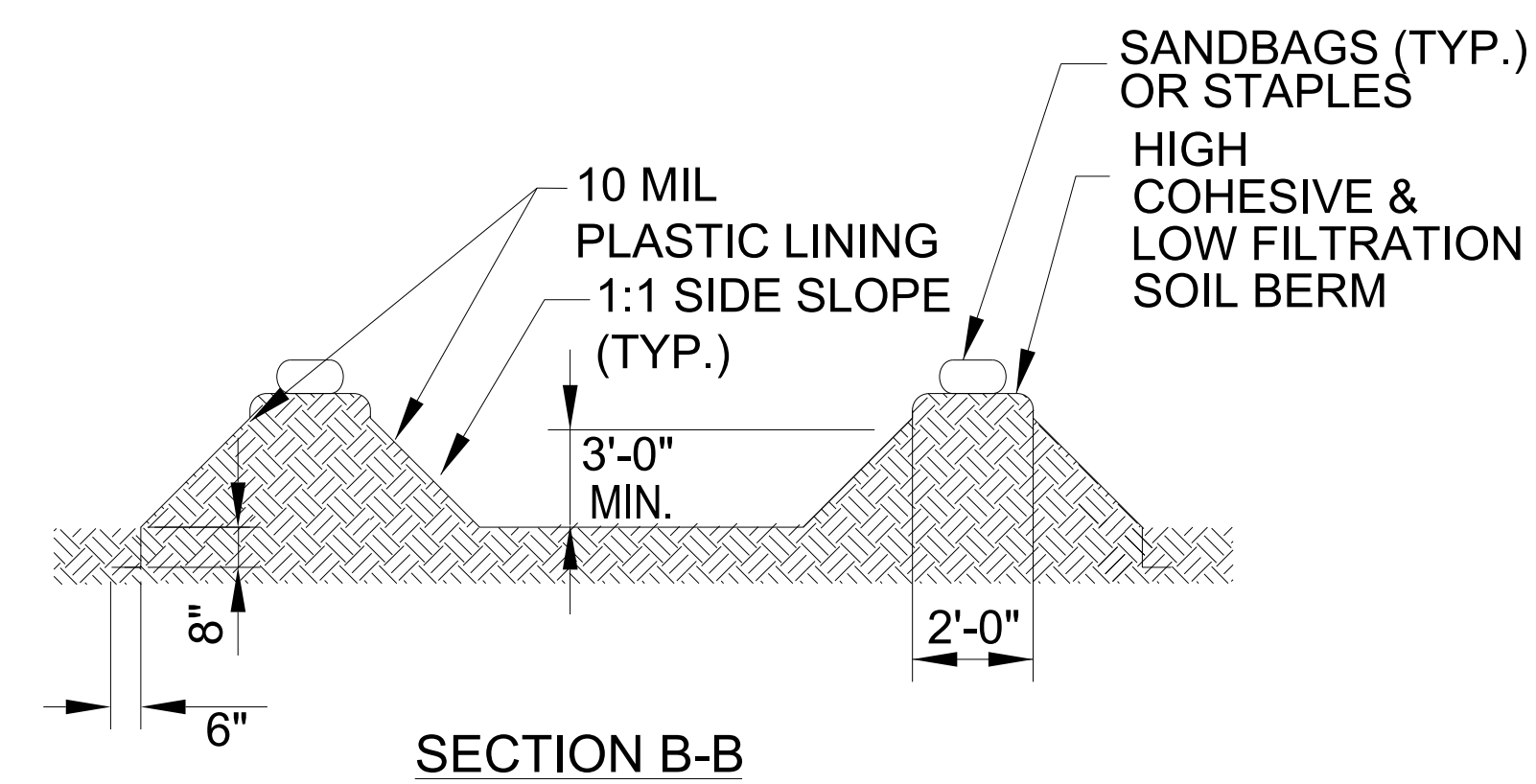
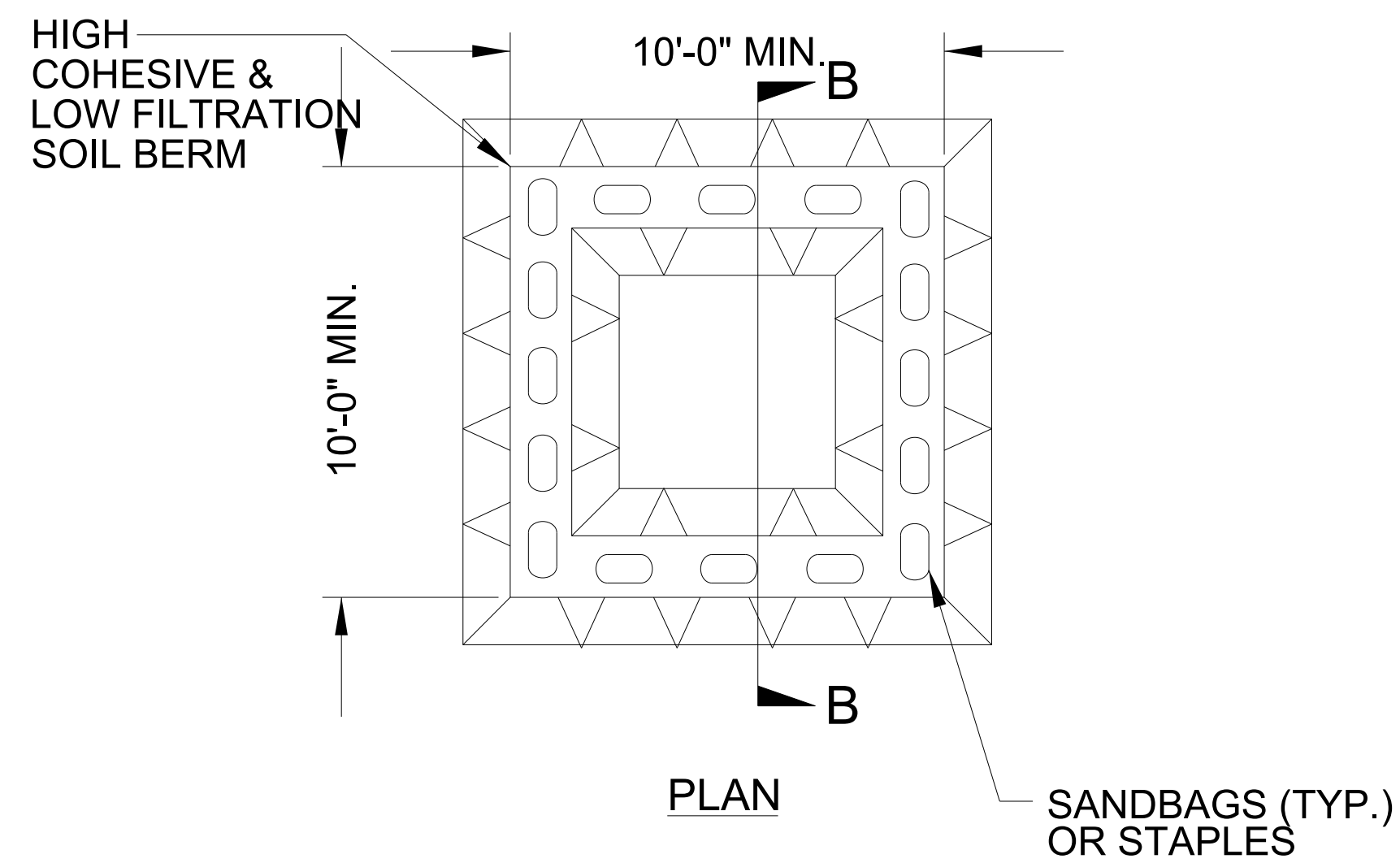

ABOVE GRADE WASHOUT STRUCTURE
NOT TO SCALE

- NOTES:**
1. ACTUAL LOCATION DETERMINED IN FIELD
 2. THE CONCRETE WASHOUT STRUCTURES SHALL BE MAINTAINED WHEN THE LIQUID AND/OR SOLID REACHES 75% OF THE STRUCTURES CAPACITY TO PROVIDE ADEQUATE HOLDING CAPACITY WITH A MINIMUM 12 INCHES OF FREEBOARD.
 3. CONCRETE WASHOUT STRUCTURE NEEDS TO BE CLEARLY MARKED WITH SIGNAGE NOTING DEVICE.

SILT FENCE COIR FIBER WATTLE BREAK DETAIL

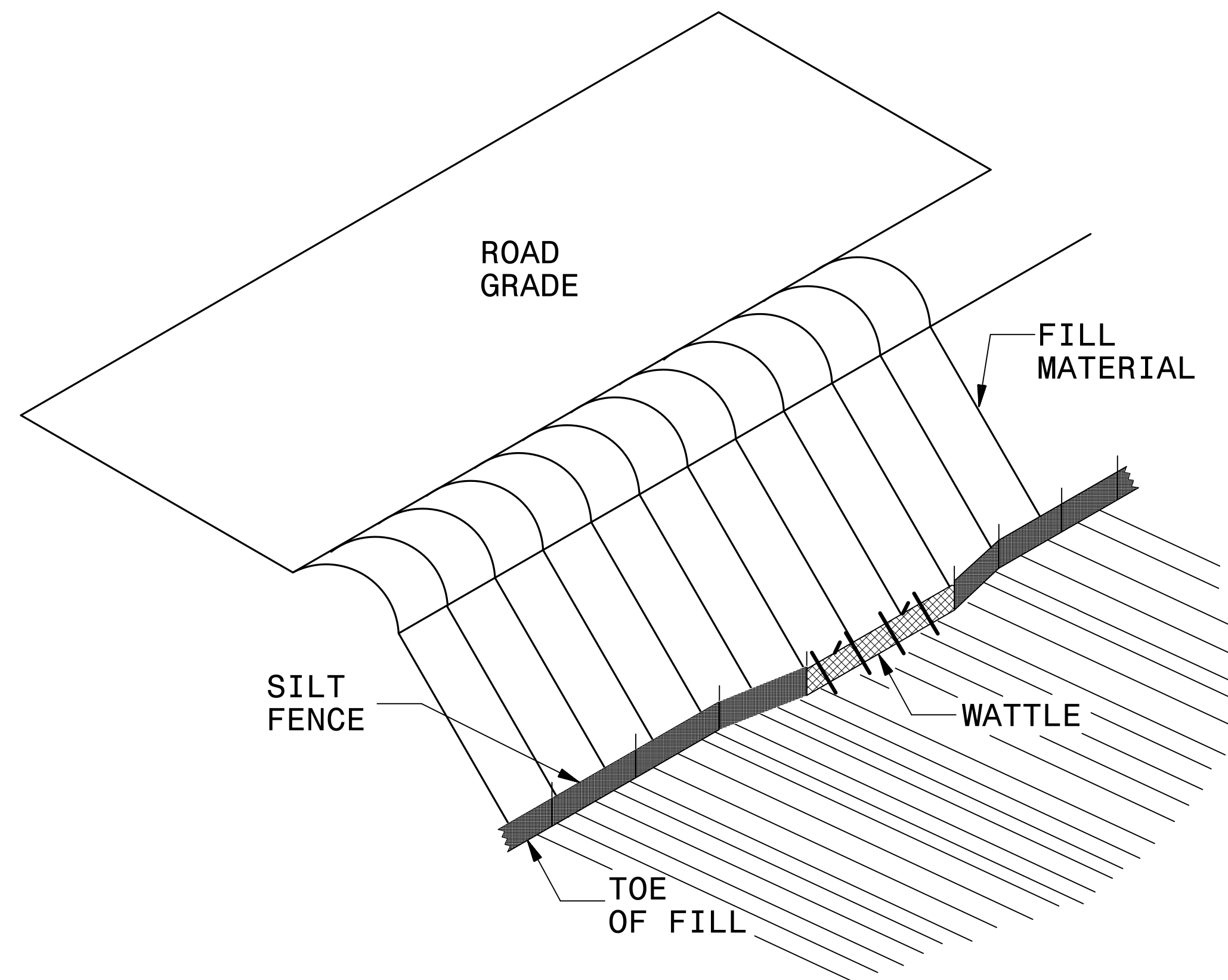

ISOMETRIC VIEW

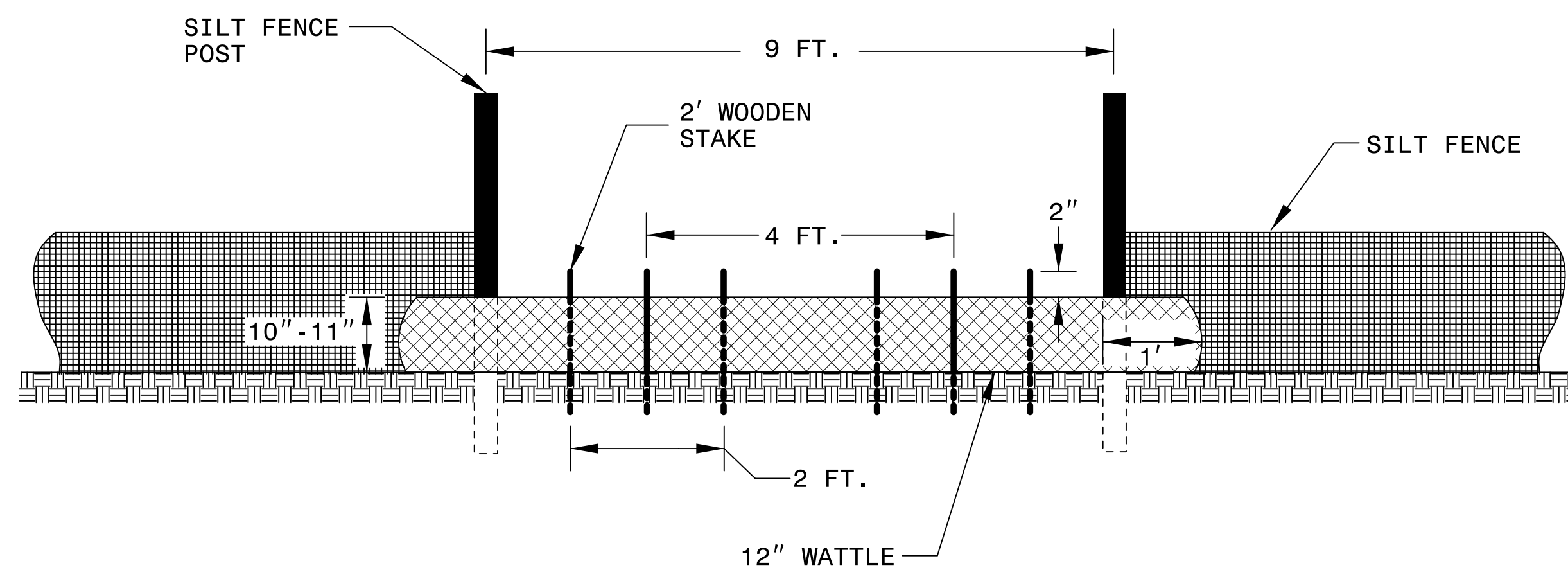

VIEW FROM SLOPE

NOTES:

USE MINIMUM 12 IN. DIAMETER COIR FIBER (COCONUT FIBER) WATTLE AND LENGTH OF 10 FT.

EXCAVATE A 1 TO 2 INCH TRENCH FOR WATTLE TO BE PLACED.

DO NOT PLACE WATTLE ON TOE OF SLOPE.

USE 2 FT. WOODEN STAKES WITH A 2 IN. BY 2 IN. NOMINAL CROSS SECTION.

INSTALL A MINIMUM OF 2 UPSLOPE STAKES AND 4 DOWNSLOPE STAKES AT AN ANGLE TO WEDGE WATTLE TO GROUND.

PROVIDE STAPLES MADE OF 0.125 IN. DIAMETER STEEL WIRE FORMED INTO A U SHAPE NOT LESS THAN 12" IN LENGTH.

INSTALL STAPLES APPROXIMATELY EVERY 1 LINEAR FOOT ON BOTH SIDES OF WATTLE AND AT EACH END TO SECURE IT TO THE SOIL.

WATTLE INSTALLATION CAN BE ON OUTSIDE OF THE SILT FENCE AS DIRECTED.

INSTALL TEMPORARY SILT FENCE IN ACCORDANCE WITH SECTION 1605 OF THE STANDARD SPECIFICATIONS.

INSET A

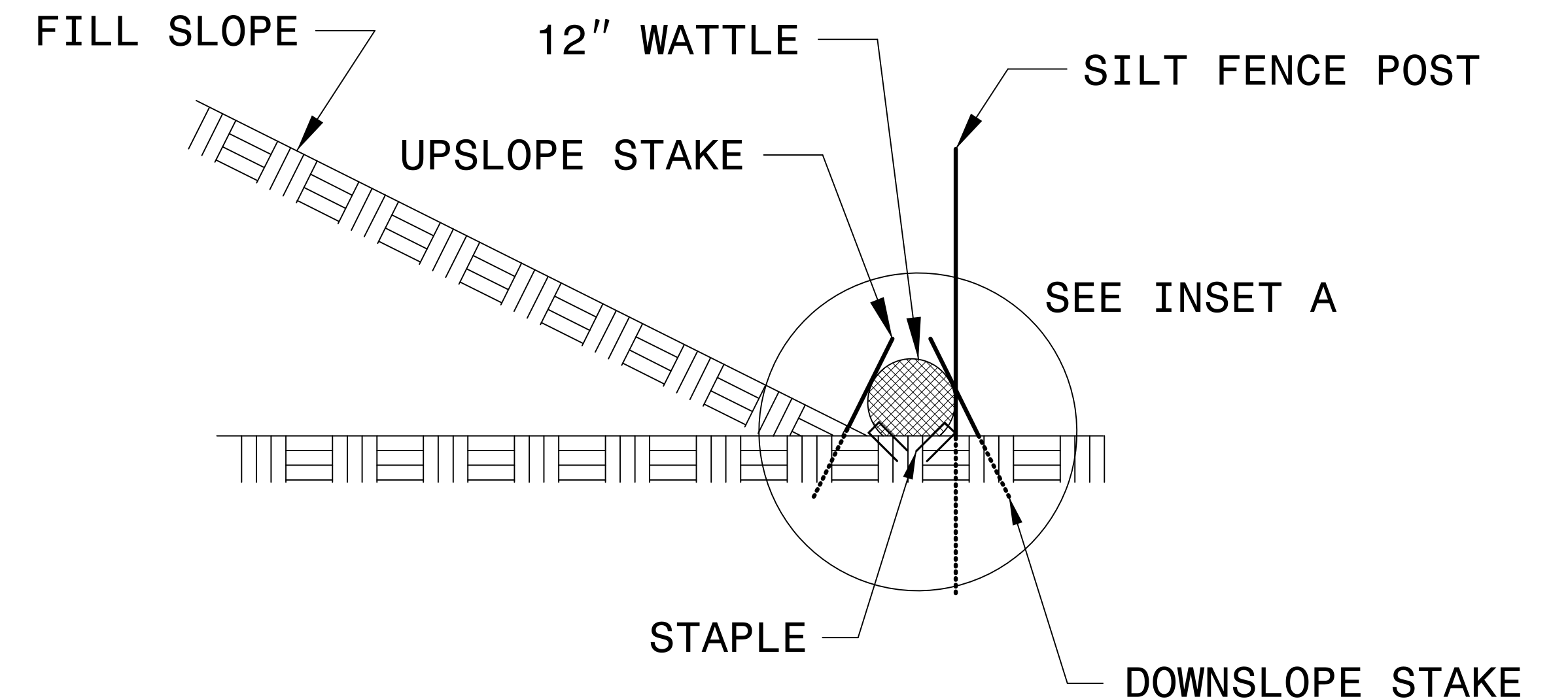
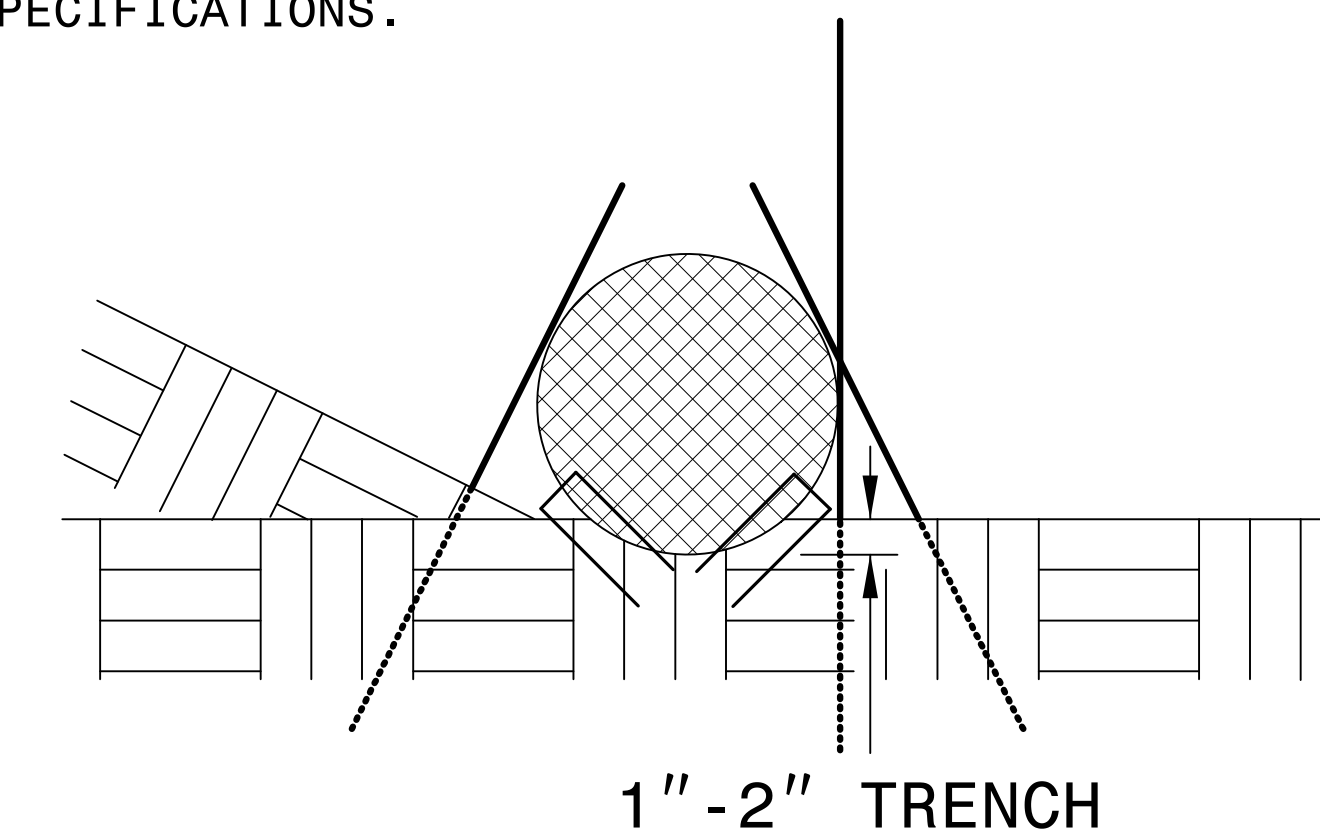

SIDE VIEW

DIVISION OF HIGHWAYS
STATE OF NORTH CAROLINA

PROJECT REFERENCE NO.	SHEET NO.
<i>B-6025</i>	<i>EC-3</i>

	STV Engineers, Inc. 900 West Trade St., Suite 715 Charlotte, NC 28202 NC License Number F-0991
---	--

SOIL STABILIZATION TIMEFRAMES

<i>SITE DESCRIPTION</i>	<i>STABILIZATION TIME</i>	<i>TIMEFRAME EXCEPTIONS</i>
PERIMETER DIKES, SWALES, DITCHES AND SLOPES	7 DAYS	NONE
HIGH QUALITY WATER (HQW) ZONES	7 DAYS	NONE
SLOPES STEEPER THAN 3:1	7 DAYS	IF SLOPES ARE 10' OR LESS IN LENGTH AND ARE NOT STEEPER THAN 2:1, 14 DAYS ARE ALLOWED.
SLOPES 3:1 OR FLATTER	14 DAYS	7 DAYS FOR SLOPES GREATER THAN 50' IN LENGTH.
ALL OTHER AREAS WITH SLOPES FLATTER THAN 4:1	14 DAYS	NONE, EXCEPT FOR PERIMETERS AND HQW ZONES.

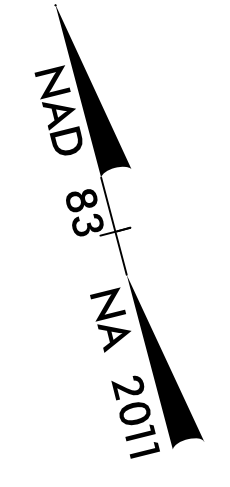

ENVIRONMENTALLY SENSITIVE AREA
SEE PROJECT SPECIAL PROVISIONS

DETOUR CONSTRUCTION PHASE (CLEARING AND GRUBBING)

CLEARING AND GRUBBING
EROSION CONTROL FOR
CONSTRUCTION SHEET 4

NOTE:
PLACE TEMPORARY ROCK SEDIMENT DAMS TYPE - B
AND TEMPORARY ROCK SILT CHECKS TYPE - A AT
DRAINAGE OUTLETS.

NOTE:
PERIMETER EROSION CONTROL MEASURES SHALL BE
INSTALLED DURING CLEARING AND GRUBBING PHASE.

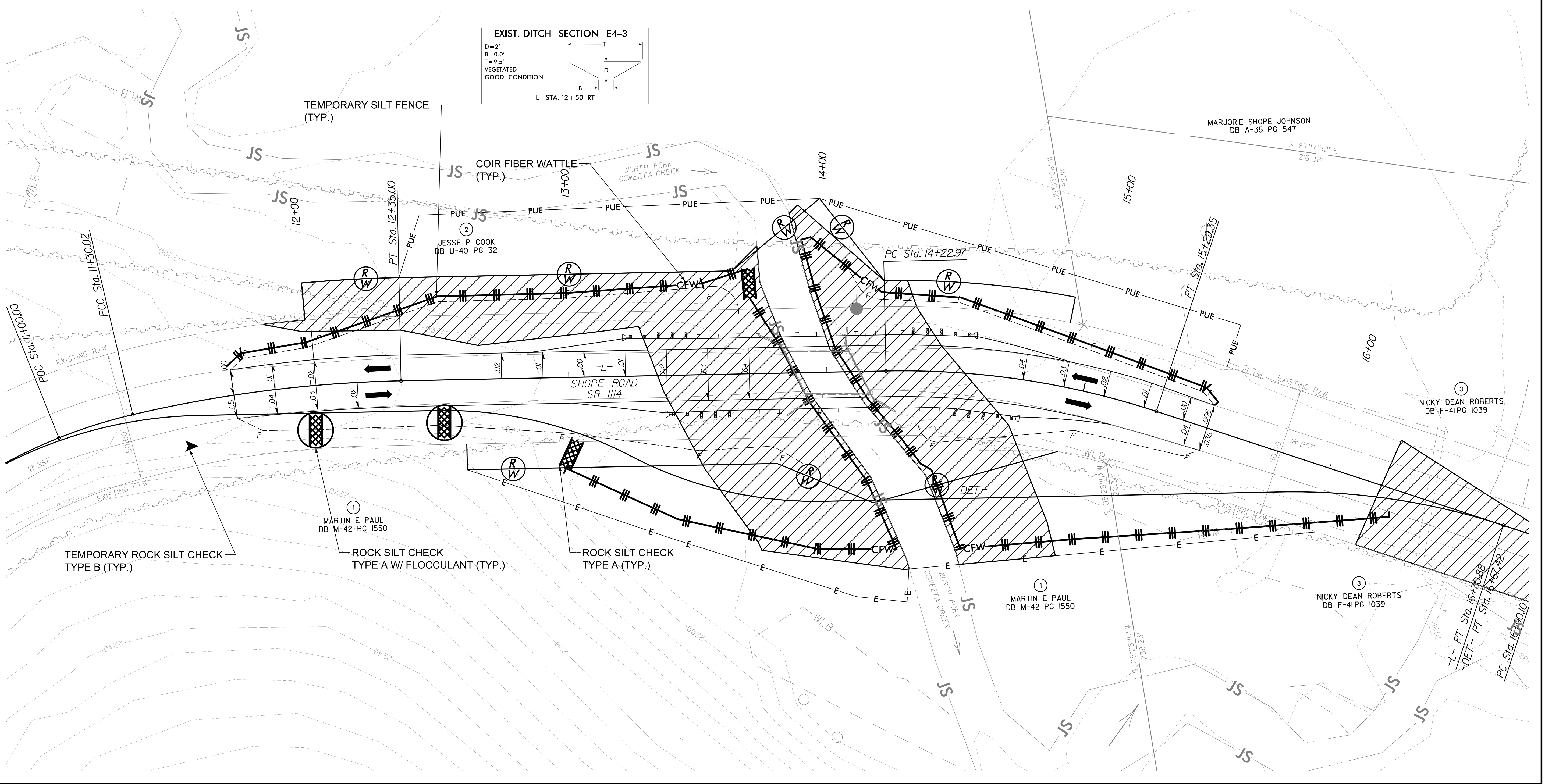
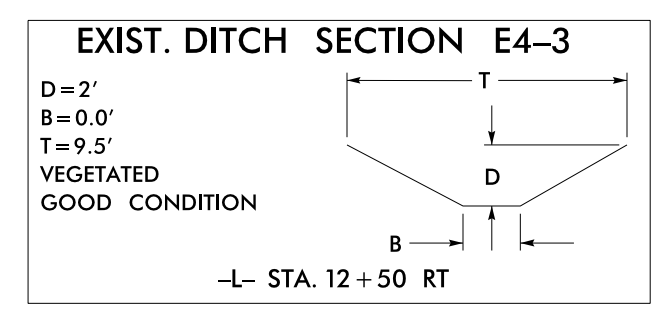

TEMPORARY CULVERT CONSTRUCTION SEQUENCE

STA. 14+34 -DET-

stv STV Engineers, Inc.
 900 West Trade St., Suite 715
 Charlotte, NC 28202
 NC License Number E-0991

PHASE I

1. CONSTRUCT TEMPORARY STILLING BASIN
2. CONSTRUCT IMPERVIOUS DIKE AND 36" TEMPORARY PIPE, DIVERTING FLOW
3. DEWATER CONSTRUCTION AREA AND REMOVE ANY ACCUMULATED SILT
4. CONSTRUCT TEMPORARY CULVERT PIPES

PHASE II

5. REMOVE IMPERVIOUS DIKES AND TEMPORARY PIPE, DIVERTING FLOW THROUGH TEMPORARY CULVERT
6. REMOVE SPECIAL STILLING BASIN
7. TIE SILT FENCE AT CULVERT ENDS AND COMPLETE DETOUR

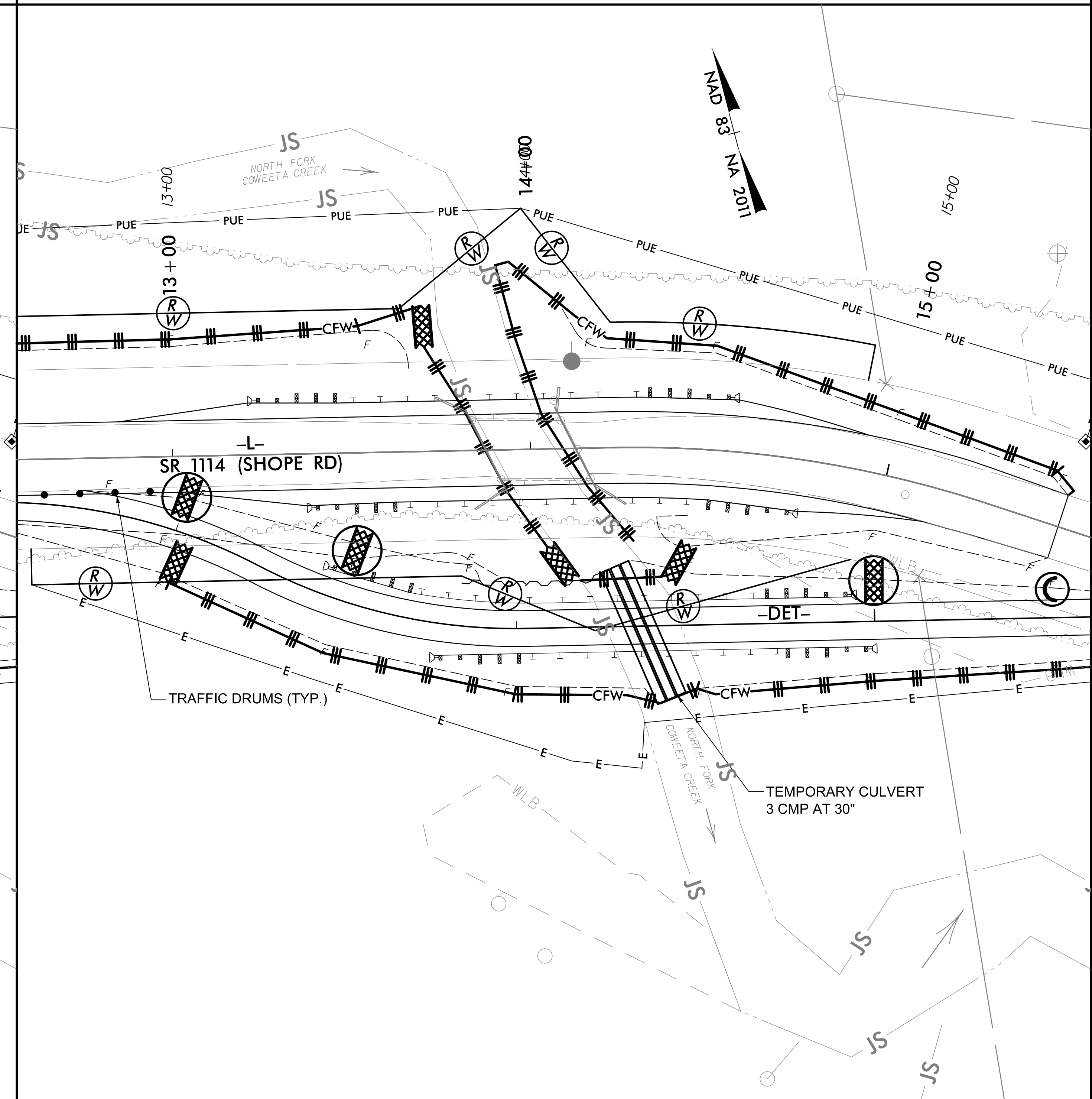
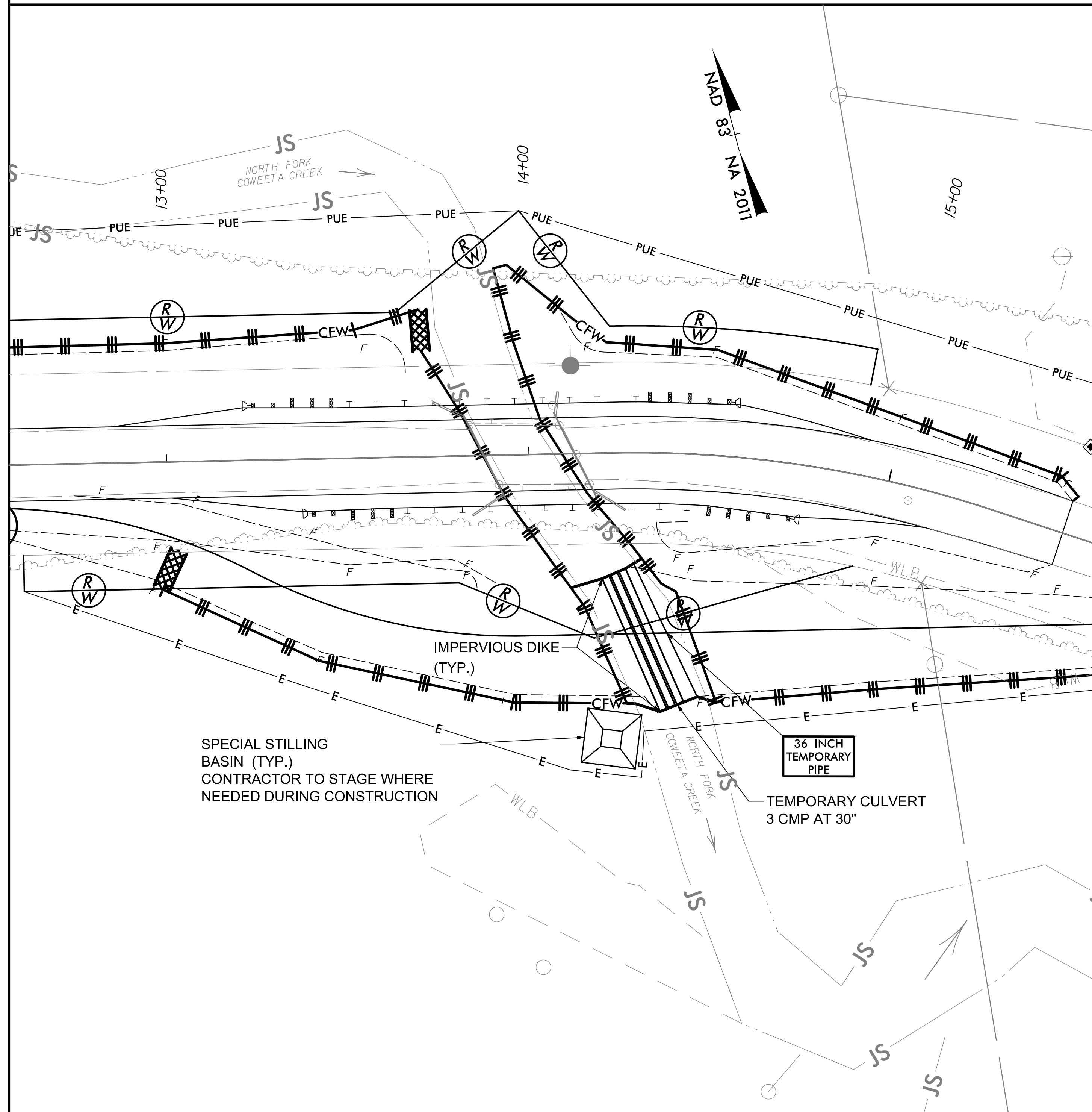

CLEARING AND GRUBBING
EROSION CONTROL FOR
CONSTRUCTION SHEET 4

stv STV Engineers, Inc.
900 West Trade St., Suite 715
Charlotte, NC 28202
NC License Number F-0991

NOTE:
PLACE TEMPORARY ROCK SEDIMENT DAMS TYPE - B
AND TEMPORARY ROCK SILT CHECKS TYPE - A AT
DRAINAGE OUTLETS.

NOTE:
PERIMETER EROSION CONTROL MEASURES SHALL BE
INSTALLED DURING CLEARING AND GRUBBING PHASE.

CLEARING & GRUBBING

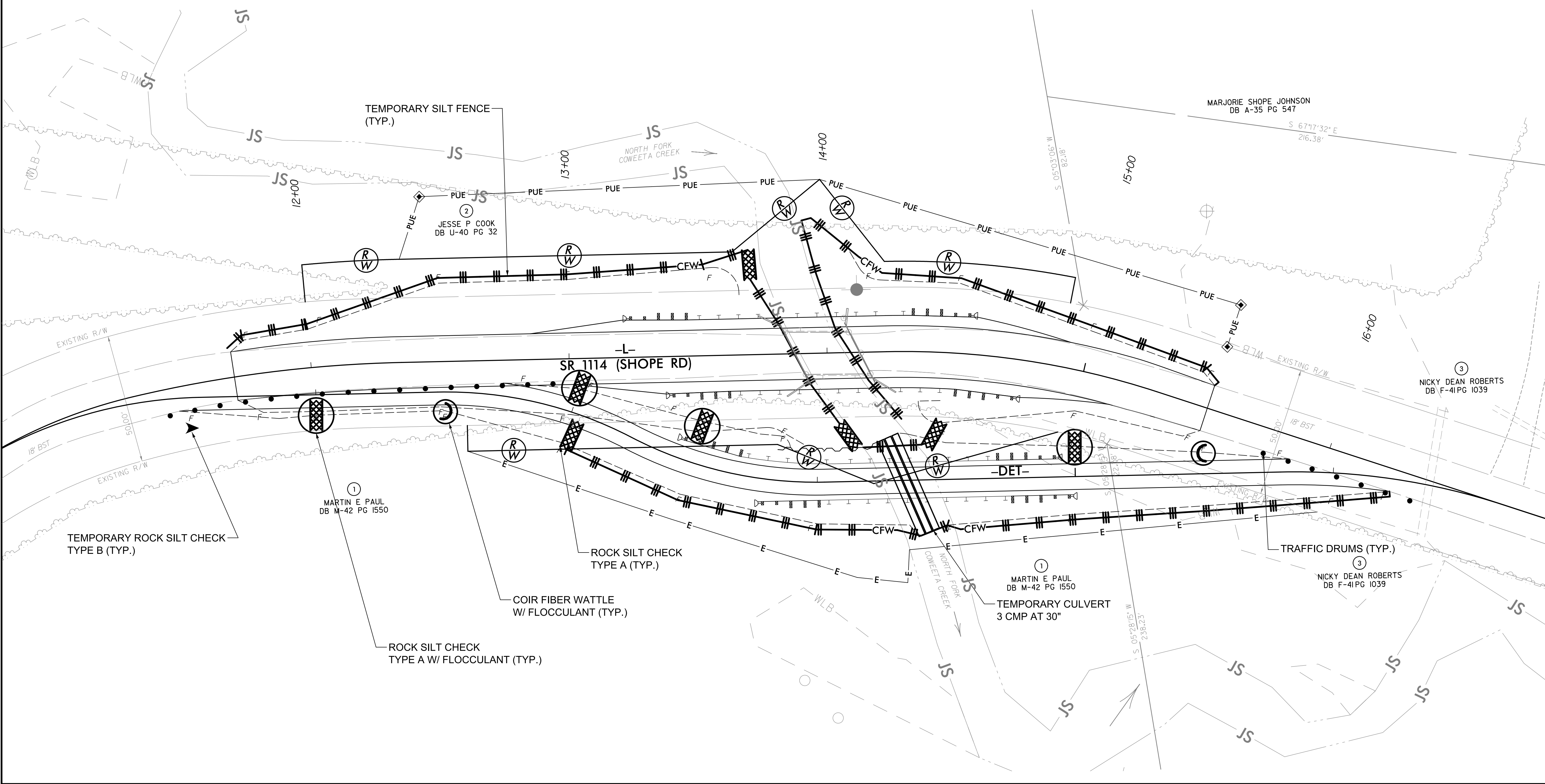
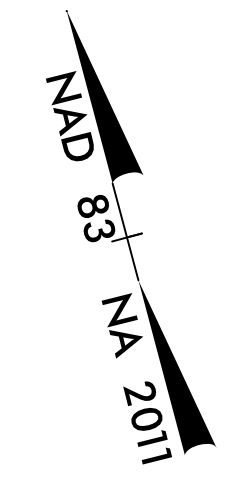

CULVERT CONSTRUCTION SEQUENCE STA. 14+01 -L-

PHASE I

1. CONSTRUCT TEMPORARY STILLING BASIN
2. CONSTRUCT IMPERVIOUS DIKE AND 36" TEMPORARY PIPE, DIVERTING FLOW
3. DEWATER CONSTRUCTION AREA AND REMOVE ANY ACCUMULATED SILT
4. CONSTRUCT ALUMINUM BOX CULVERT

PHASE II

5. CONSTRUCT INLET CHANNEL IMPROVEMENTS
6. REMOVE IMPERVIOUS DIKES AND TEMPORARY PIPE, DIVERTING FLOW THROUGH CULVERT
7. TIE SILT FENCE AT CULVERT ENDS AND COMPLETE ROADWAY
8. AFTER REMOVAL OF DETOUR, COMPLETE OUTLET CHANNEL IMPROVEMENTS
9. REMOVE SPECIAL STILLING BASIN

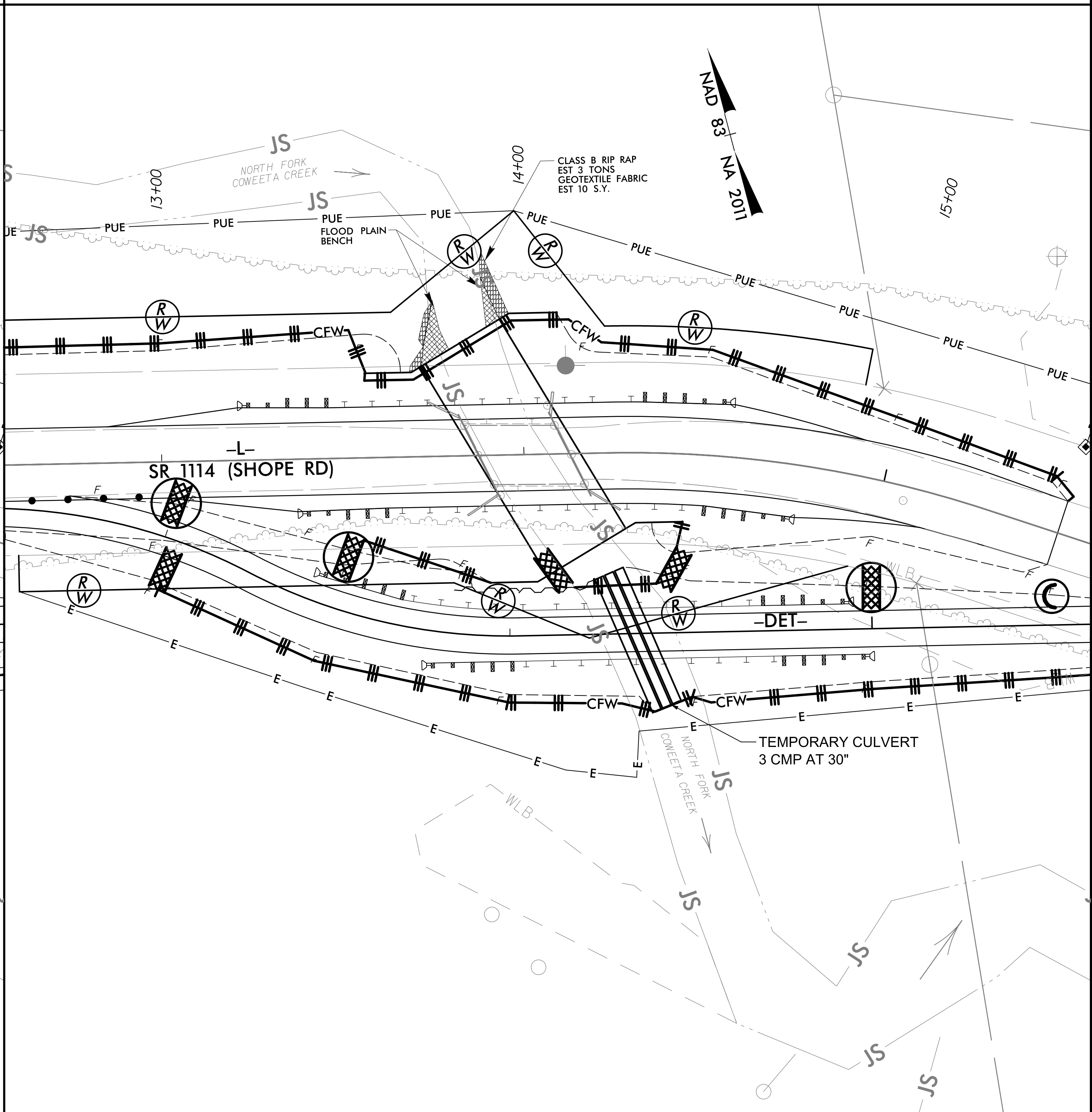
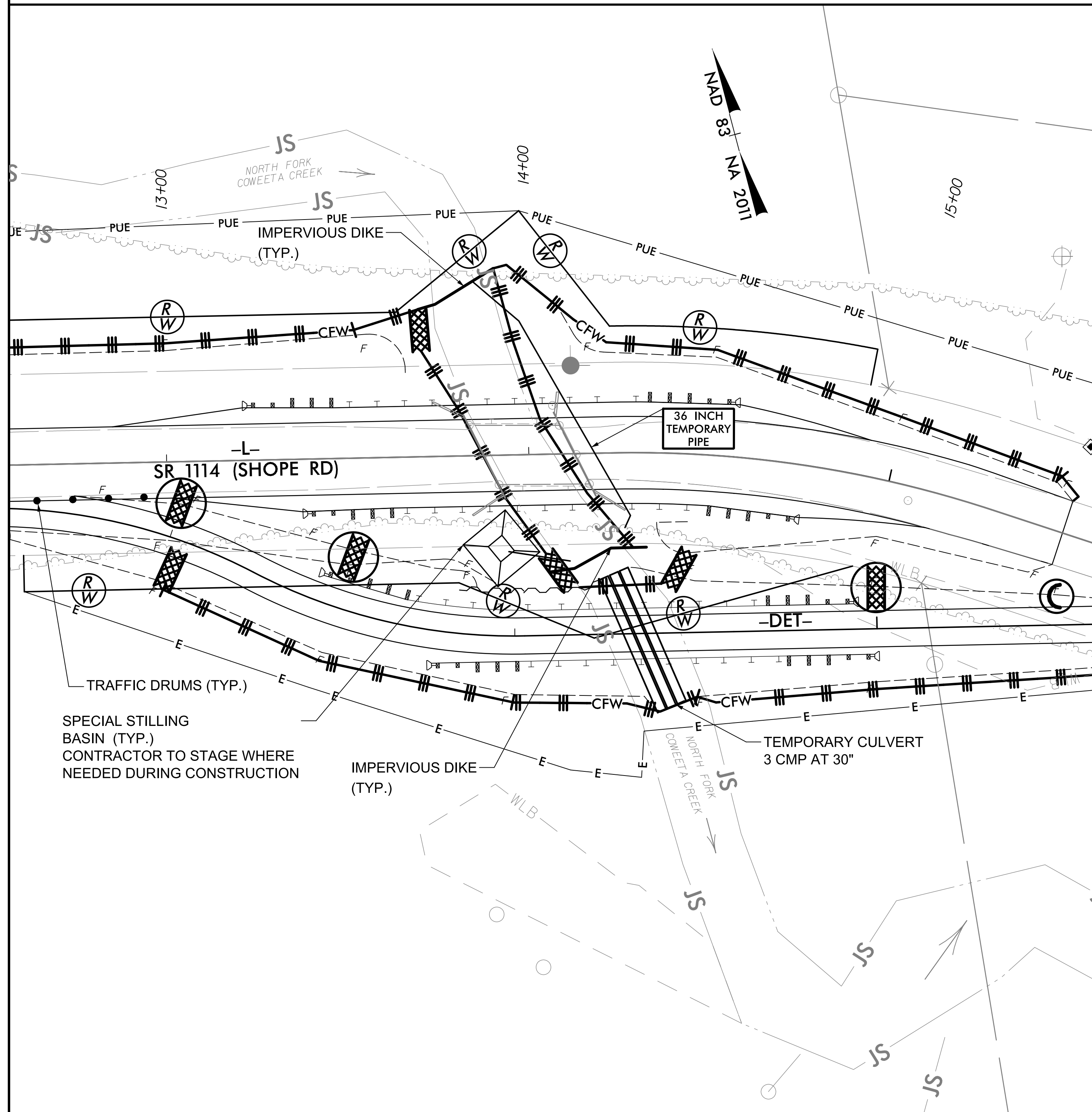

FINAL GRADING – PHASE 1

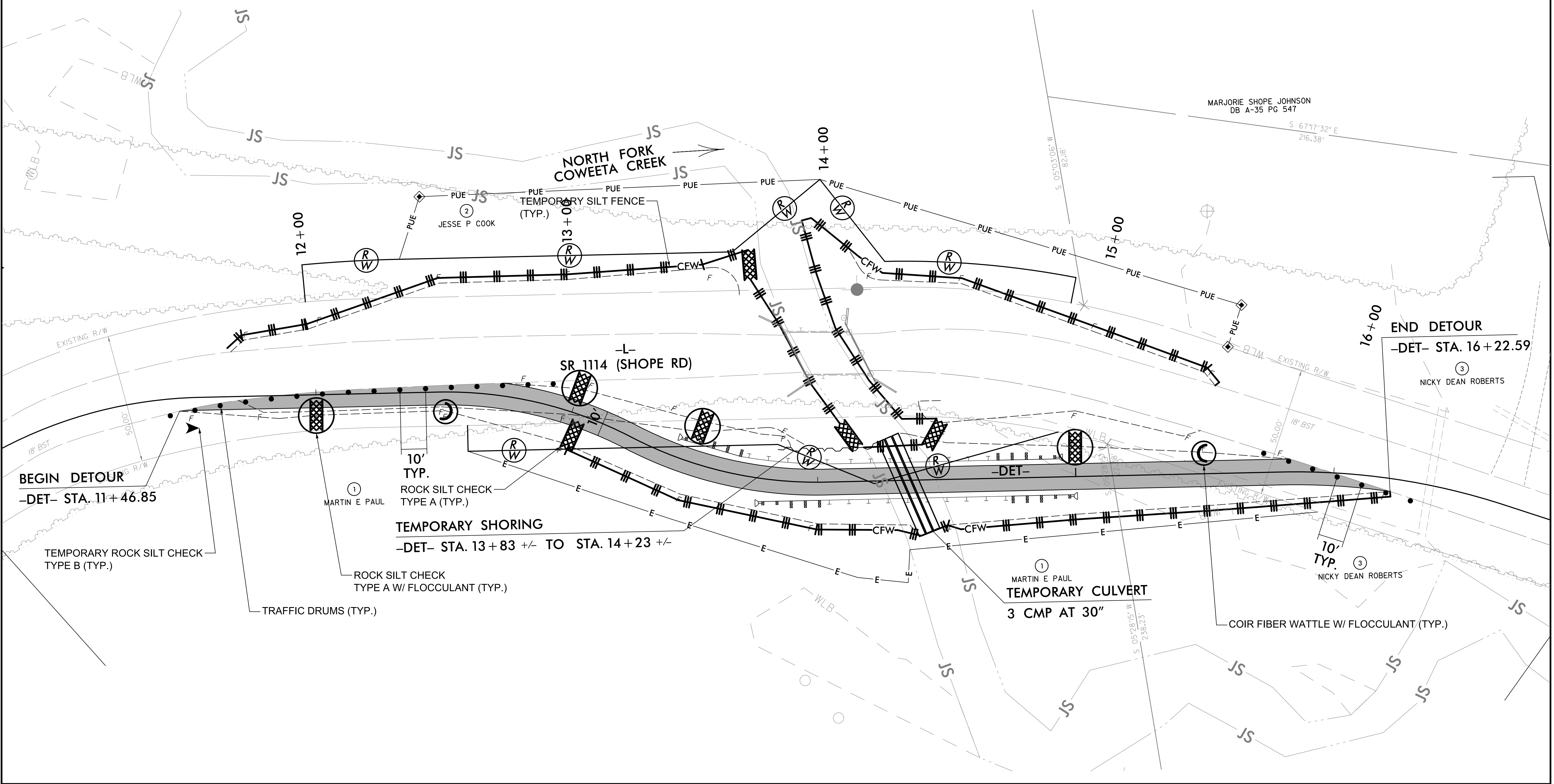
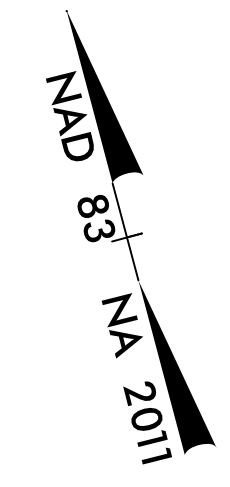

FINAL GRADING - PHASE 2

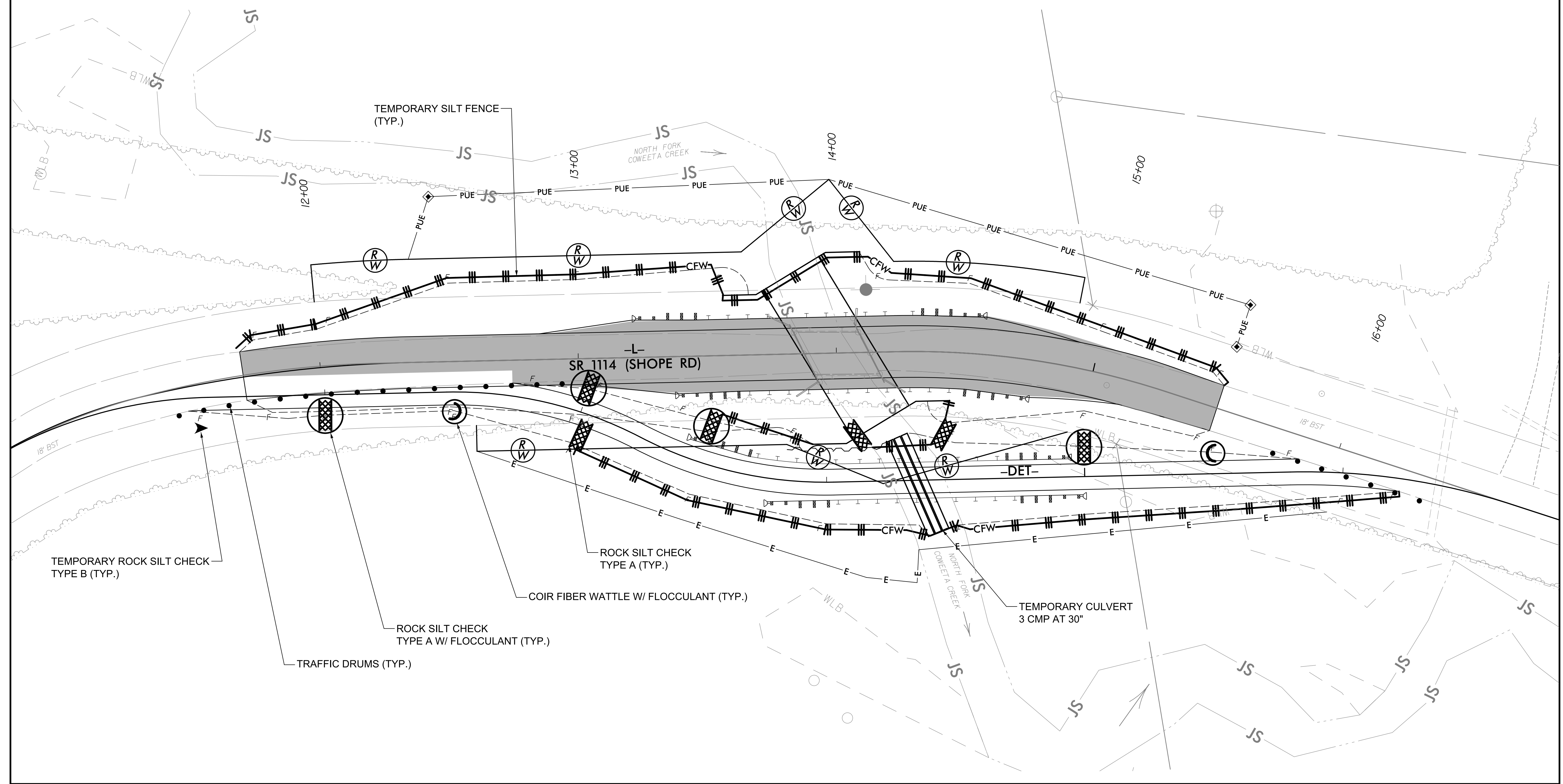
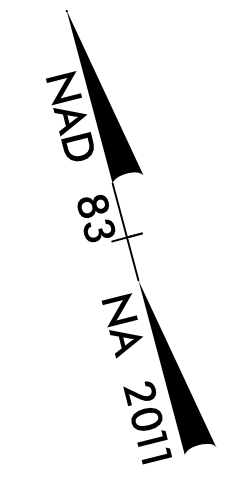

FINAL GRADING - PHASE 3

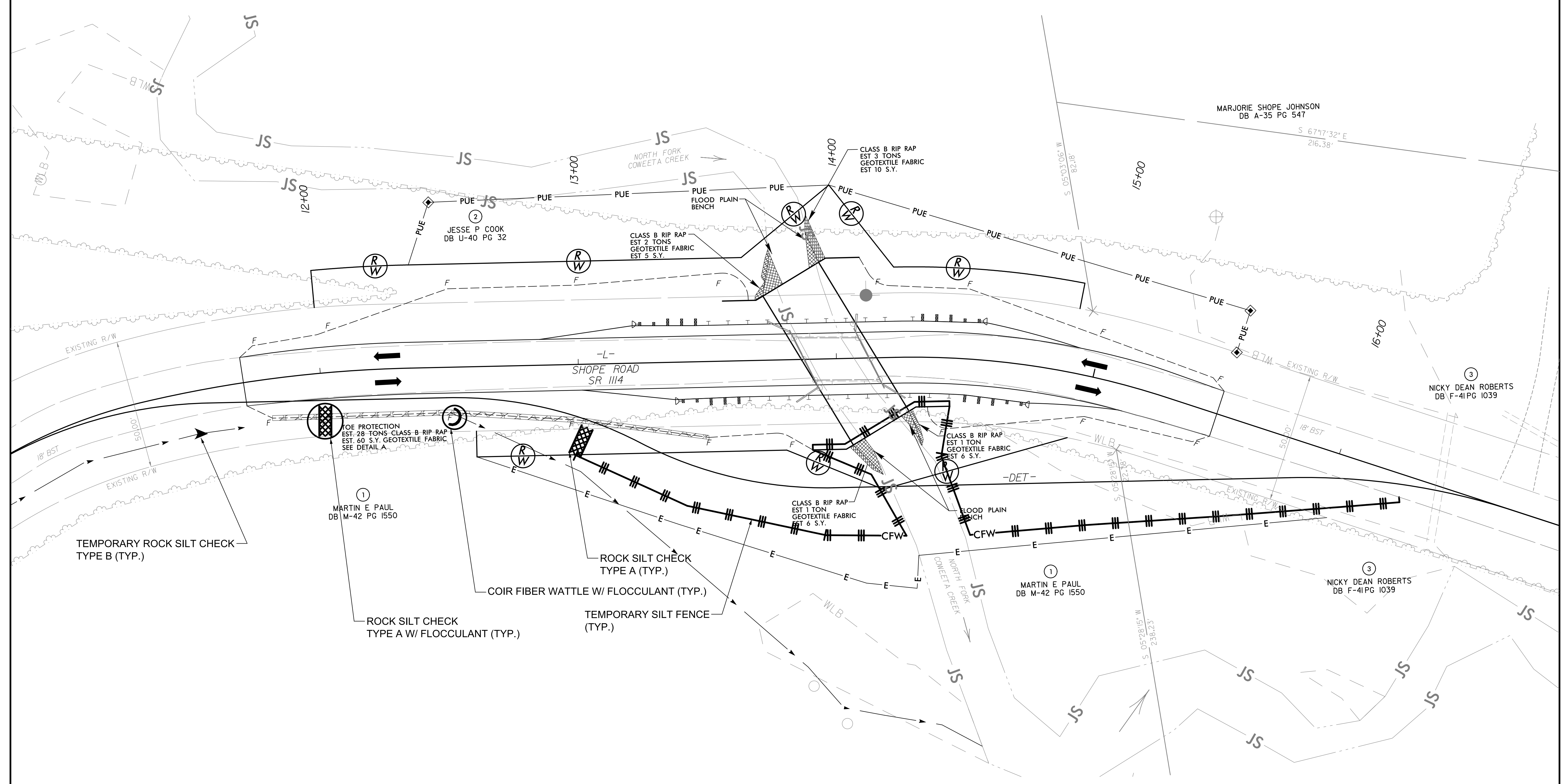
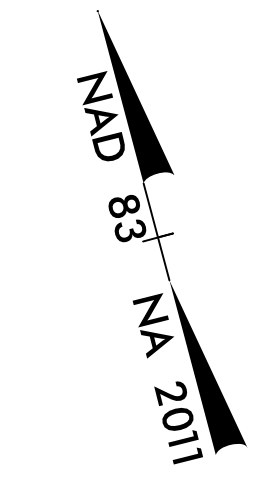

TEMPORARY ROCK SILT CHECK TYPE B (TYP.)

1
MARTIN E PAUL
DB M-42 PG 1550

ROCK SILT CHECK TYPE A W/ FLOCCULANT (TYP.)

COIR FIBER WATTLE W/ FLOCCULANT (TYP.)

ROCK SILT CHECK TYPE A (TYP.)

TEMPORARY SILT FENCE (TYP.)

2
JESSE P COOK
DB U-40 PG 32

CLASS B RIP RAP
EST 2 TONS
GEOTEXTILE FABRIC
EST 5 S.Y.

CLASS B RIP RAP
EST 1 TON
GEOTEXTILE FABRIC
EST 6 S.Y.

CLASS B RIP RAP
EST 1 TON
GEOTEXTILE FABRIC
EST 6 S.Y.

CLASS B RIP RAP
EST 3 TONS
GEOTEXTILE FABRIC
EST 10 S.Y.

1
MARTIN E PAUL
DB M-42 PG 1550

3
NICKY DEAN ROBERTS
DB F-41 PG 1039

3
NICKY DEAN ROBERTS
DB F-41 PG 1039

STATE	STATE PROJECT REFERENCE NO.	SHEET NO.	TOTAL SHEETS
N.C.	3-6025	RF-1	1
STATE PROJ. NO.	F.A. PROJ. NO.	DESCRIPTION	



PLANTING DETAILS

SEEDLING / LINER BARER ROOT PLANTING DETAIL

HEALING IN

1. Locate a healing-in site in a shady, well protected area.
2. Excavate a flat bottom trench 12 inches deep and provide drainage.

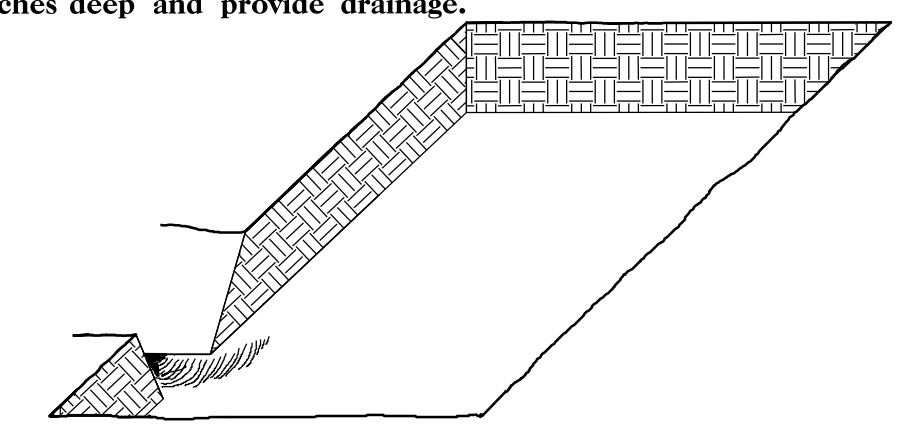

3. Jackfill the trench with 2 inches well rotted sawdust. Place a 2 inch layer of well rotted sawdust at a sloping angle at one end of the trench.

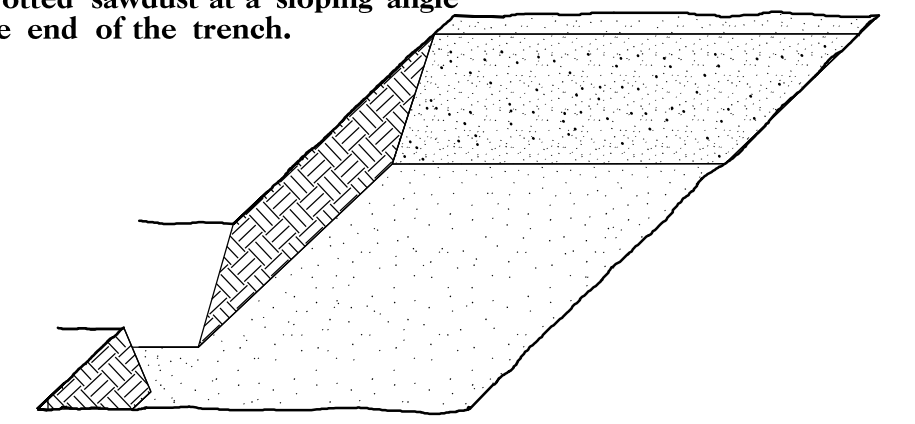

4. Place a single layer of plants against the sloping end so that the root collar is at ground level.

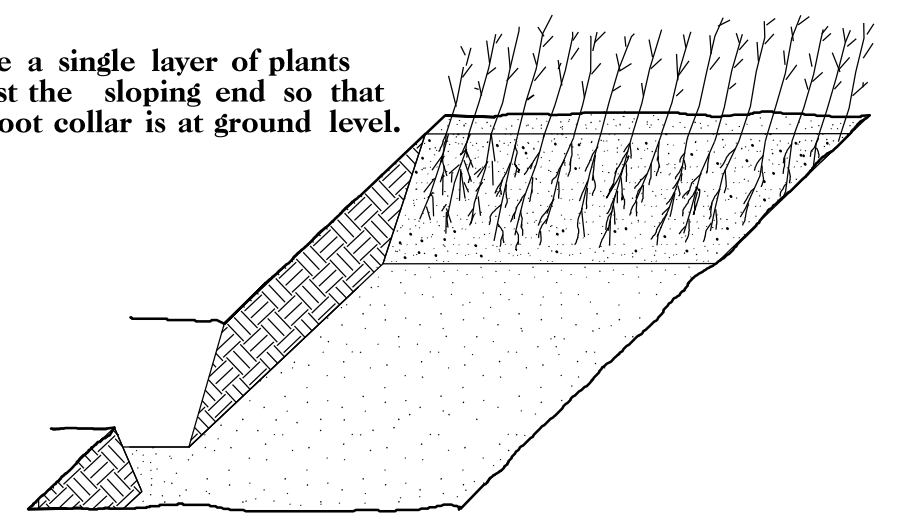

5. Place a 2 inch layer of well rotted sawdust over the roots maintaining a sloping angle.

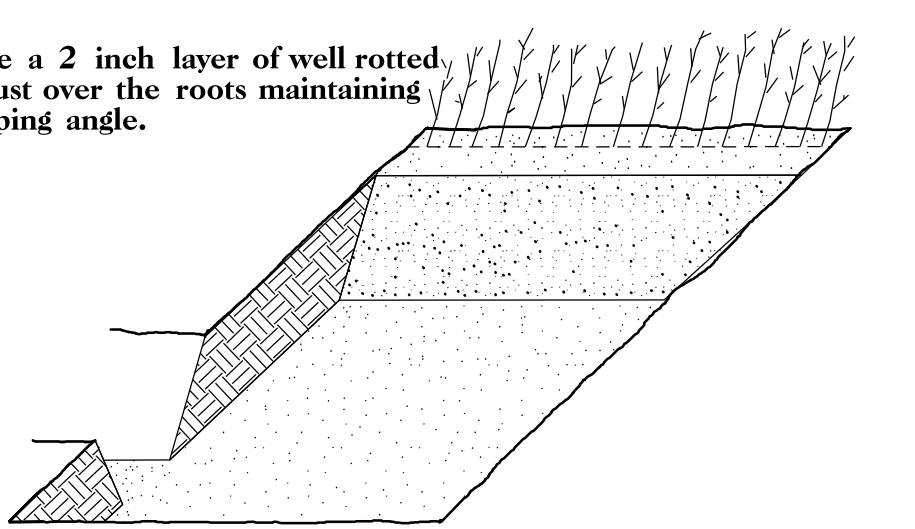

6. Repeat layers of plants and sawdust as necessary and water thoroughly.

DOUBLE PLANTING METHOD USING THE K3C PLANTING BAR

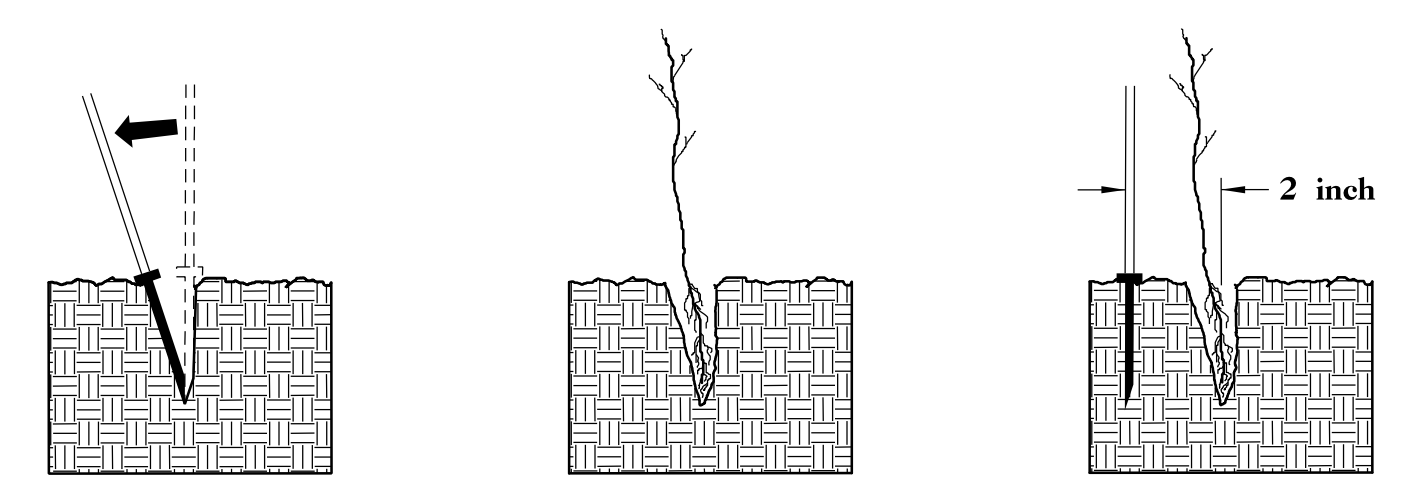

1. Insert planting bar as shown and pull handle toward planter.
2. Remove planting bar and place seedling at correct depth.
3. Insert planting bar 2 inches toward planter from seedling.

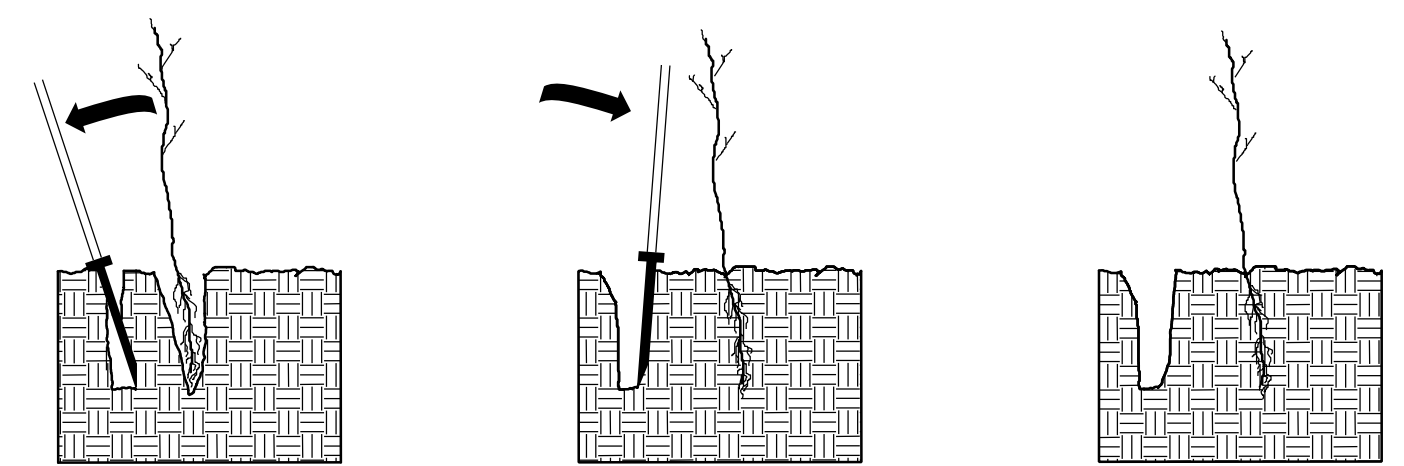

4. Pull handle of bar toward planter, firming soil at bottom.
5. Push handle forward firming soil at top.
6. Leave compaction hole open. Water thoroughly.

PLANTING NOTES:

PLANTING BAG
During planting, seedlings shall be kept in a moist canvas bag or similar container to prevent the root systems from drying.



K3C PLANTING BAR
Planting bar shall have a blade with a triangular cross section, and shall be 12 inches long, 4 inches wide and 1 inch thick at center.

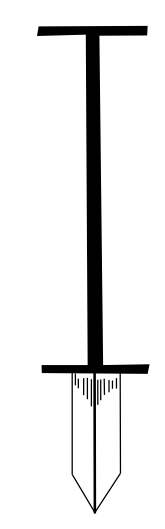

ROOT PRUNING
All seedlings shall be root pruned, if necessary, so that no roots extend more than 10 inches below the root collar.

REFORESTATION

- TREE REFORESTATION SHALL BE PLANTED 6 FT. TO 10 FT. ON CENTER, RANDOM SPACING, AVERAGING 8 FT. ON CENTER, APPROXIMATELY 680 PLANTS PER ACRE.

REFORESTATION

MIXTURE, TYPE, SIZE, AND FURNISH SHALL CONFORM TO THE FOLLOWING:

25%	LIRIODENDRON TULIPIFERA	TULIP POPLAR	12 in - 18 in 3R
25%	PLATANUS OCCIDENTALIS	AMERICAN SYCAMORE	12 in - 18 in 3R
25%	FRAXINUS PENNSYLVANICA	GREEN ASH	12 in - 18 in 3R
25%	BETULA NIGRA	RIVER BIRCH	12 in - 18 in 3R

REFORESTATION DETAIL SHEET

N.C.D.O.T. - ROADSIDE ENVIRONMENTAL UNIT

PROJECT TIP: B-6025

CONTRACT: DN00480

PROJECT REFERENCE NO.	SHEET NO.
B-6025	UO-1

STATE OF NORTH CAROLINA
DIVISION OF HIGHWAYS

**UTILITIES BY OTHERS
MACON COUNTY**

LOCATION: BRIDGE NO. 550244 OVER NORTH FORK SHOPE CREEK ON SR 1114 (SHOPE ROAD)
TYPE OF WORK: AERIAL POWER & TELEPHONE

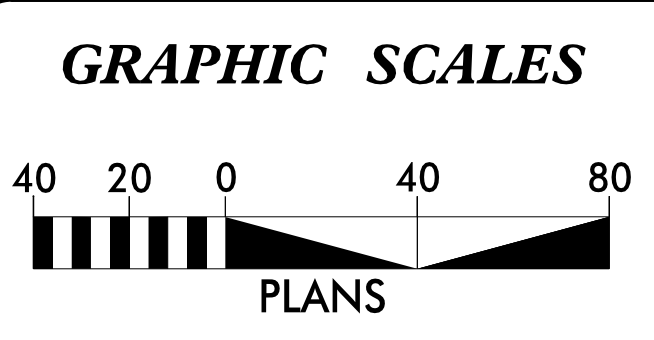
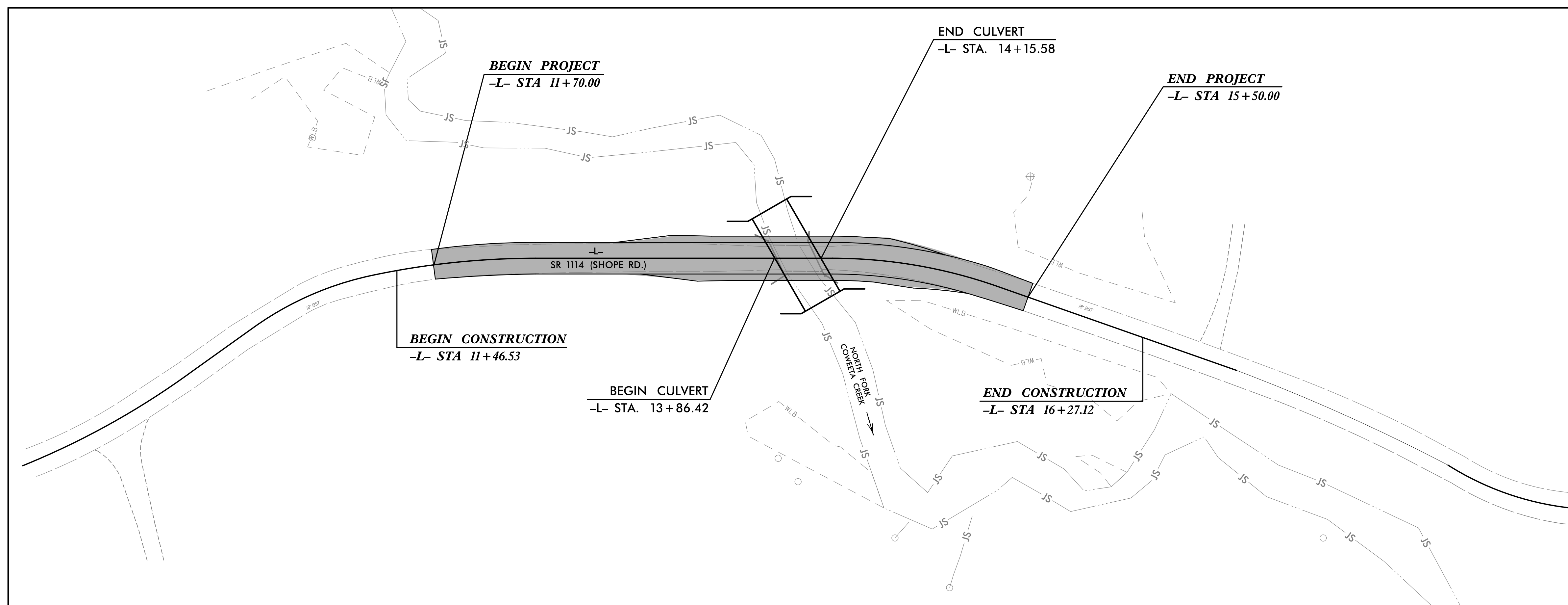
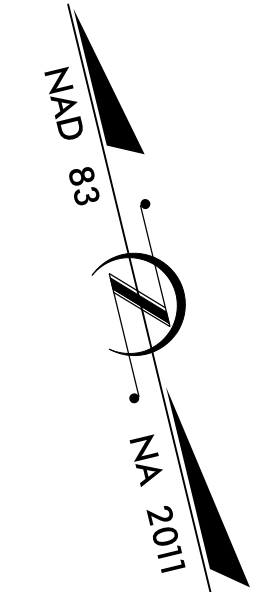
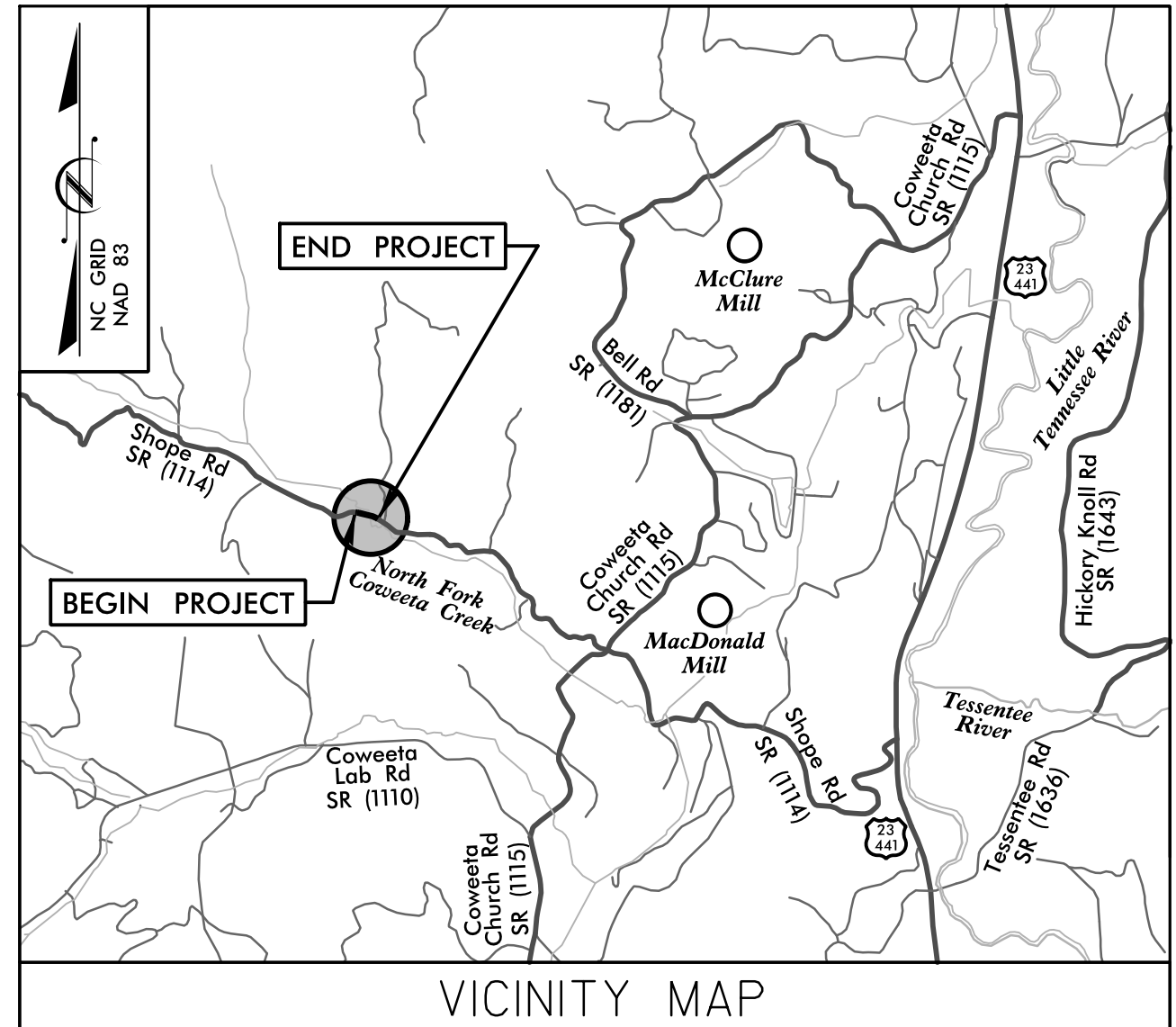

INDEX OF SHEETS

SHEET NO.	DESCRIPTION
UO-1	TITLE SHEET
UO-2	UTILITIES BY OTHERS PLAN SHEET

- UTILITY OWNERS ON PROJECT**
- (1) POWER - DUKE ENERGY
 - (2) TELEPHONE - FRONTIER COMMUNICATIONS

PLANS PREPARED BY:

Consulting Engineers
1318-F Patton Ave.
Asheville, NC 28806
828-253-2796
NC License Number: F-1088

PREPARED FOR THE OFFICE OF:
**DIVISION OF HIGHWAYS
UTILITIES ENGINEERING
SECTION**

1591 MAIL SERVICES CENTER
RALEIGH NC 27699-1591
PHONE (919) 250-4128
FAX (919) 250-4119

Robert Golding	DIVISION 14 UTILITY COORDINATOR
Lynn Mann, P.G.	UTILITIES PROJECT COORDINATOR

3/31/17
ADDED DUKE PLAN & PUE 8/8/17

TRANSPORTATION\31614-01\MACON_244\UTILITIES\U0-2.DGN

PROJECT TIP: B-6025

CONTRACT: DN00480

STRUCTURE 550244
MACON COUNTY

PROJECT REFERENCE NO.	SHEET NO.
B-6025	U0-2

UTILITIES BY OTHERS

NOTE:
ALL PROPOSED UTILITY WORK
SHOWN ON THIS SHEET WILL
BE DONE BY OTHERS

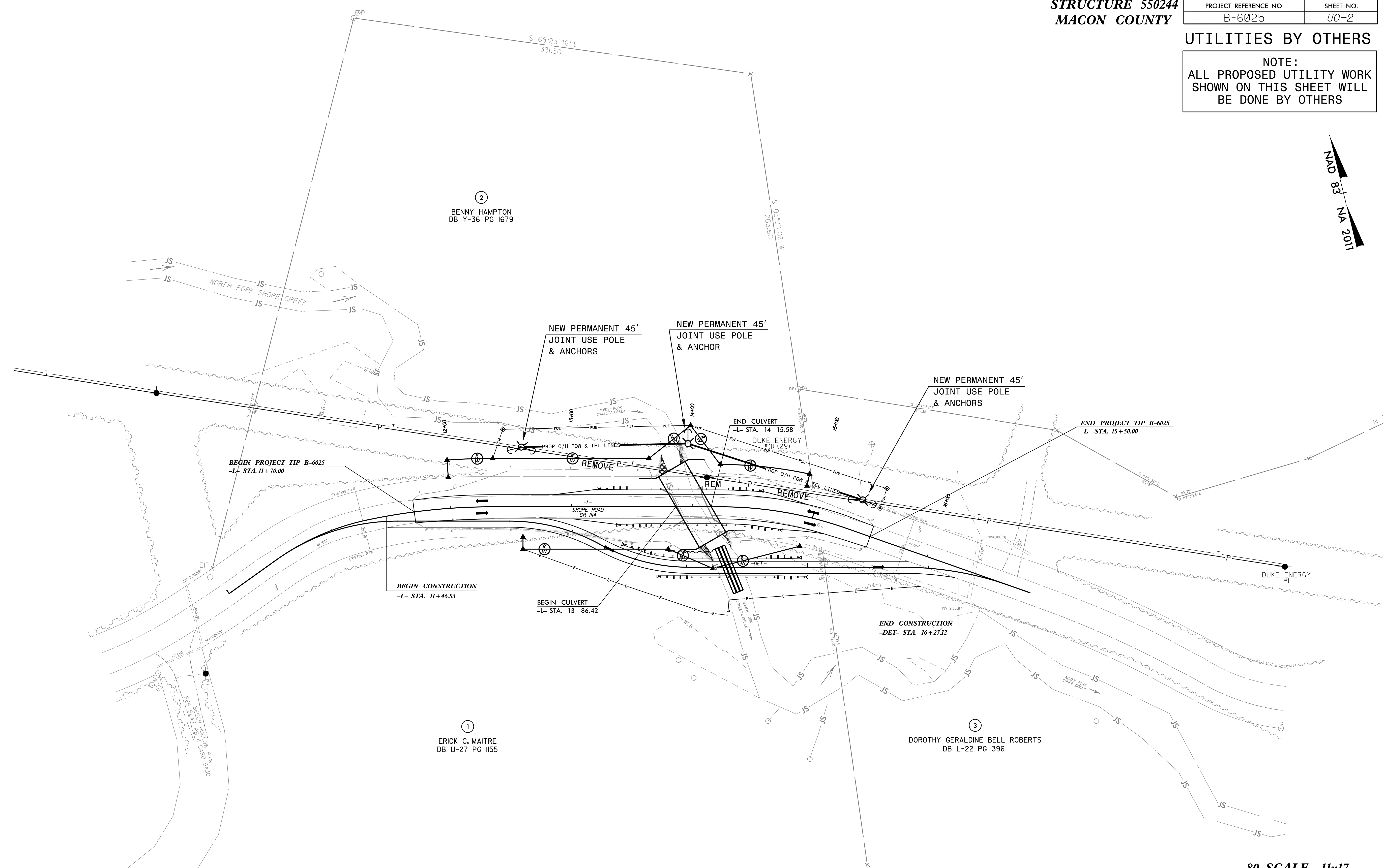
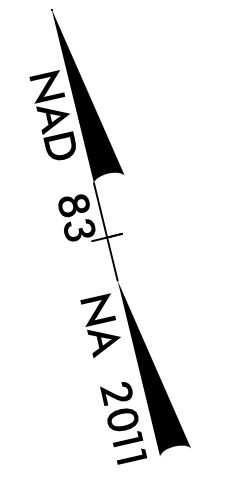

80 SCALE- 11x17

V&M
Vaughn & Melton
Consulting Engineers

Charlotte, North Carolina 704-357-0488	Tri-Cities, Tennessee 423-461-8400
Asheville, North Carolina 828-253-2796	Middlesboro, Kentucky 606-248-6600
NC License Number: F-1088	Spartanburg, South Carolina 864-574-4715

Copyright © 2006 Vaughn & Melton, Inc. All Rights Reserved.